

DMU 50

THE 3rd GENERATION DMU
even better and
more powerful!



DMU 50

Compact universal machining centre of the 3rd generation for 5-axis simultaneous machining.

Ever since the DMU 50 has been developed more than 20 years ago, standards and requirements are steadily increasing. The 3rd generation of the DMU 50 meets the requirements of 5-axis machining of the future and is characterised by innovative mechanical engineering technology. The larger working area and swivel range of the B-axis extend the range of applications of the machine. Rapid traverses of 42 m/min and a swivel speed of 30 rpm guarantee dynamic machining and up to 30 % shorter cutting cycles. The extensive cooling measures are unique in this machine class and enable maximum precision.

The latest control technology with ERGOline Control with a 21.5" multi-touch screen and CELOS guarantees optimum user-friendliness, precision and reliability. With the DMU 50 DMG MORI offers the ideal, cost-effective entry into the world of 5-sided and even 5-axis simultaneous machining.

02



1: Hydraulic component/motorsport
2: Milling head/tool manufacture





3



4



5

3: Belt fastener/automotive 4: Pump housing/fluid technology
5: Structural component/aerospace



NEW: STEALTH DESIGN FOR MAXIMUM PRODUCTION RELIABILITY

- + **Optimized lighting** in the working area
- + **Perfect visibility into the working area** based on large windows
- + **Best access to the working area as well as easy and ergonomic loading of the tool magazine**
- + **Programmable roof opening** (M-function)

AUTOMATION – PERFECT SOLUTION TO INCREASE YOUR EFFICIENCY

- + **Perfect coordination** between machine and automation system
- + Optimal integration of automation from the side with **unlimited access to the working area**
- + **Standardized and customized automation solutions** in the fields of pallet and workpiece handling:
 - PH 150 – standardized pallet handling** for up to 24 pallets and a workpiece weight of up to 250 kg
 - WH CELL – modular construction kit** enables an efficient, customer individual solution

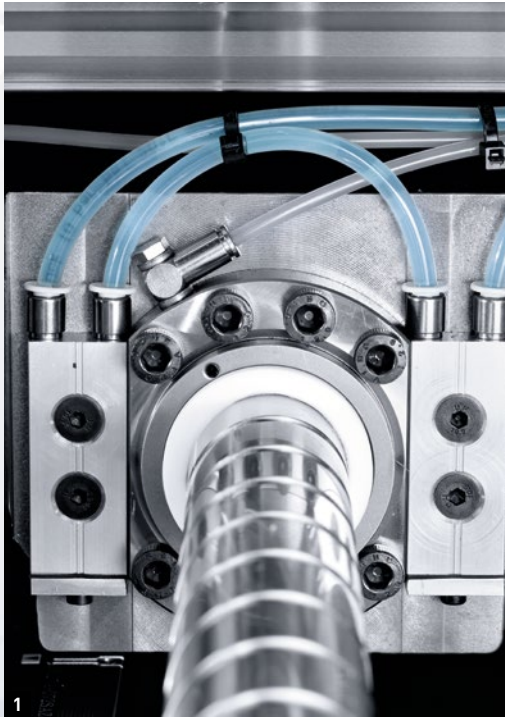

1+2: Cooled ball screw nuts and guideways
3: Optimal overview of and accessibility to the hydraulics



Now even more precise with:

- + Linear scales in all axes
- + Directly driven ball screws
- + Cooled ball screw nuts, guideways and bearings
- + Two cooled table bearings (B and C-axes)
- + Cooled motor spindle

The best DMU 50

- + 78 % larger working area
- + 40 % faster rapid traverses, 42 m/min as standard
- + 28 % larger swivel range, swivel range of $-35^{\circ}/+110^{\circ}$
- + speedMASTER spindles rated at up to 20,000 rpm
- + Tool magazines with up to 120 pockets

DMU 50

Highest accuracy thanks to direct drives and the integrated cooling concept.

With its low centre of mass and stable design, the single-piece machine bed provides improved static and dynamic stability. In combination with directly driven ball screws, linear scales and extensive cooling, this machine enables a level of precision unrivalled in this class.

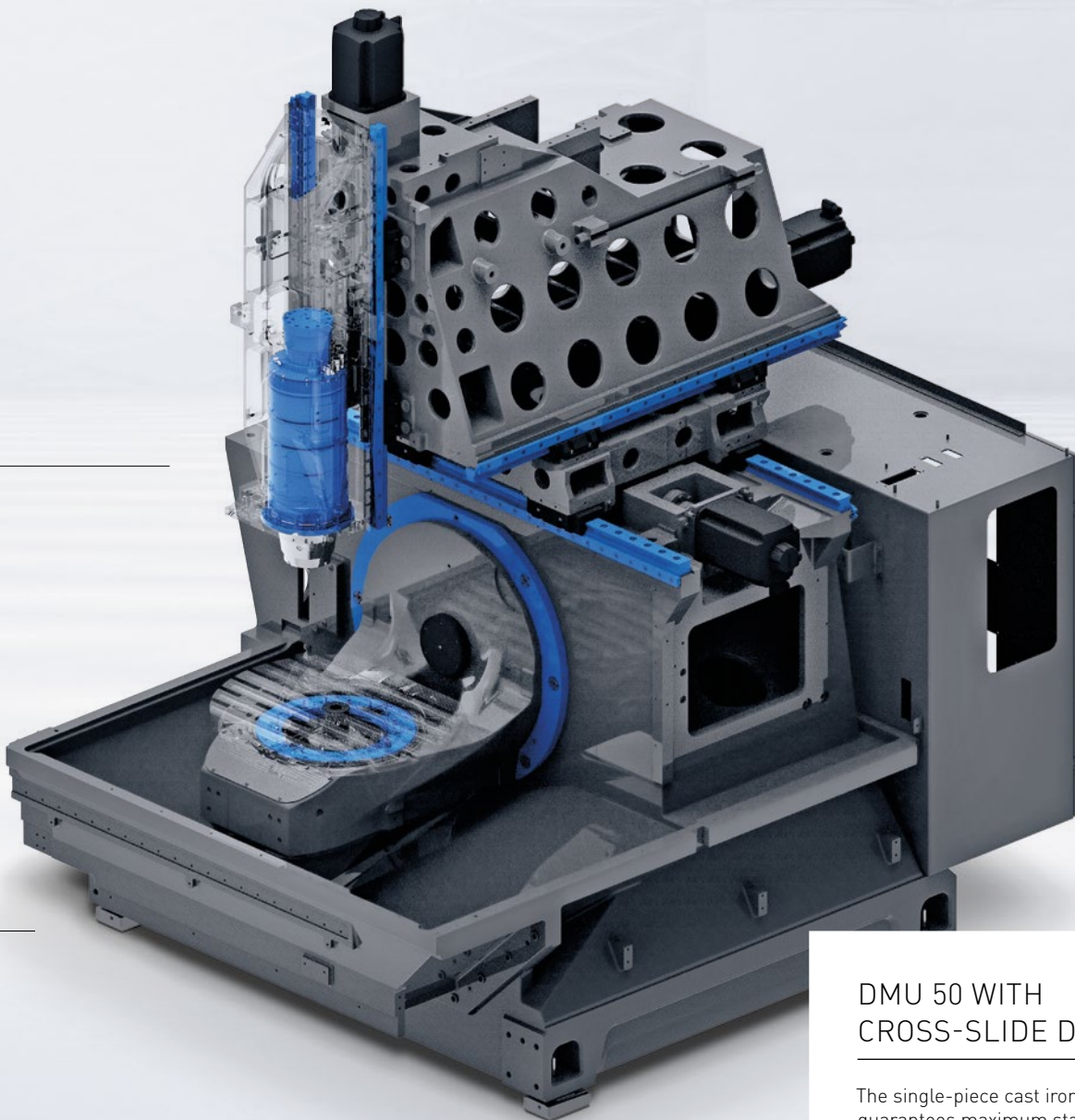

05

DMU 50 WITH CROSS-SLIDE DESIGN:

The single-piece cast iron machine bed guarantees maximum stability.

DMU 50

Innovative technology and top-class options for any application.

The DMU 50's new tool magazine with 30, 60 or 120 pockets and a rapid double gripper make it possible to load the tools during machining. This, combined with short chip-to-chip times, saves time throughout the production process. Additionally, as the tools are stored outside of the working area they cannot be contaminated by chips. With optional, high-performance speedMASTER motor spindles rated at up to 20,000 rpm or 200 Nm, the machine has enough power to handle difficult materials and challenging applications.



B-axis: $-35^{\circ} / +110^{\circ}$

C-axis: 360°

78% LARGER WORKING AREA

with swivelling rotary table for 5-axis simultaneous machining of workpieces weighing up to 300 kg.

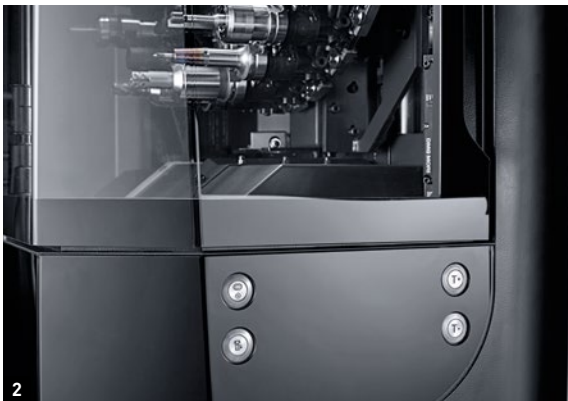
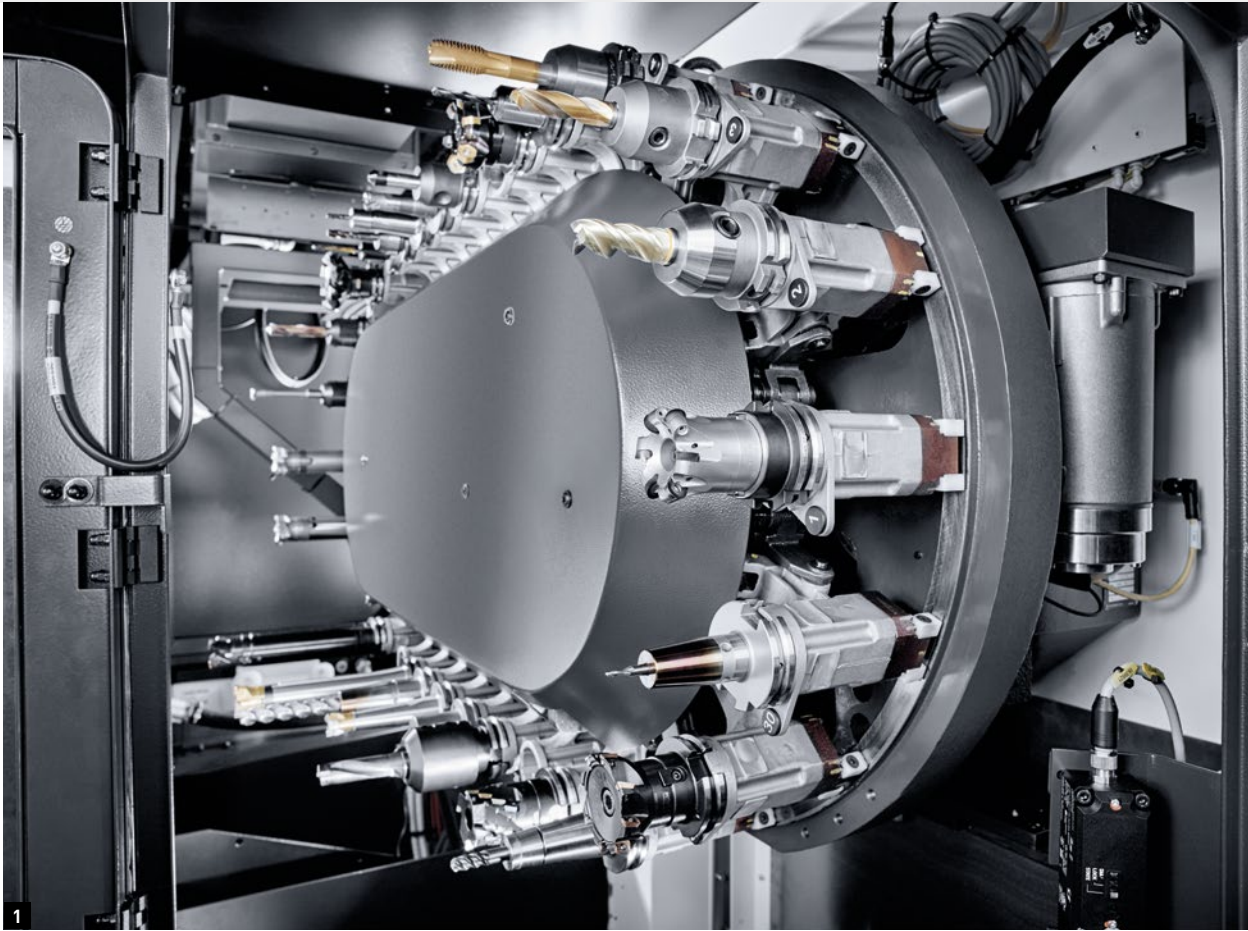

1 + 2: Tool magazine for 30, 60 or 120 pockets

2: Set-up station for loading the magazine quickly and easily during the machining process

3: Powerful spindles:

15,000 rpm / 21 kW / 111 Nm speedMASTER spindle SK40 / HSK-A63

15,000 rpm / 46 kW / 200 Nm speedMASTER spindle SK40 / HSK-A63 (optional)

20,000 rpm / 35 kW / 130 Nm speedMASTER spindle SK40 / HSK-A63 (optional)



APP MENU

Like on a smart phone, the operator has direct access to all available applications through the APP MENU.

SMARTkey

Personalized authorization of the operator: Individually adapted access rights to the control system and the machine.

CELOS ON THE ERGOline CONTROL WITH 21.5" MULTI-TOUCH SCREEN

Standardized

Simple machine operation for all new high-tech machines made by DMG MORI.

End-to-end

End-to-end administration, documentation and visualization of order, process and machine data.

Open

Direct data import from MES and ERP systems. Integration of any external program and web contents.

Measurable

With the DMG MORI MESSENGER all status information of the linked machines and devices is available at a glance. Regular and automated reports boost transparency in production.

Future-proof

Simple PLC-independent CELOS update to the latest version from every existing version. The data is reliably migrated and all functions supported by the PLC will then be available to the full extent.

DMU 50

CELOS – Optimal ease of use.

CELOS offers a standardized user interface for all new high-tech DMG MORI machines. CELOS APPs enable end-to-end administration, documentation and visualization of order, process and machine data. This also simplifies, standardizes and automates machine operation. Standard APPs support the machine operator during preparation, optimization and systematic processing of production orders.

High-end CNCs for safe processes and maximum precision.



SIEMENS 840D SOLUTIONLINE

- + SINUMERIK Operate
- + 3D simulation
- + Processing from the hard drive
- + Quick editing of large programs
- + Simple, graphically supported set-up
- + Comprehensive tool management

Advantages

- + Easy interactive programming
- + Programming with no additional documentation
- + Wide range of canned cycles
- + Safety thanks to pre-production simulations
- + Sophisticated tool handling



HEIDENHAIN TNC 640

- + Shop floor or DIN-ISO programming
- + 3D workpiece simulation
- + Graphical programming
- + Coordinate transformation
- + Rapid program creation with visual programming

Advantages

- + Familiar and proven HEIDENHAIN user interface
- + For rapid programming
- + Graphical programming support
- + Convenient, thanks to the comprehensive selection of canned cycles



FANUC MAPPS IVS

- + FANUC based
- + User memory with large capacity of 6GB as standard
- + Equipped with simple and easy-to-follow conversational programming function
- + Quick access to required information by manual data searchfunction
- + Two multi-touch panels

Advantages

- + 3D machining simulation for easy geometry checking
- + 4-window display for checking required machine information at the same time
- + Improved set-ups by displaying required machine information according to the operation



DMU 50

Power Diagrams

speedMASTER-spindle SK40/HSK-A63

15,000 rpm / 21 kW / 111 Nm

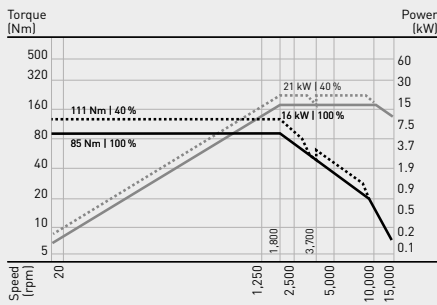

speedMASTER-spindle SK40/HSK-A63*

15,000 rpm / 46 kW / 200 Nm

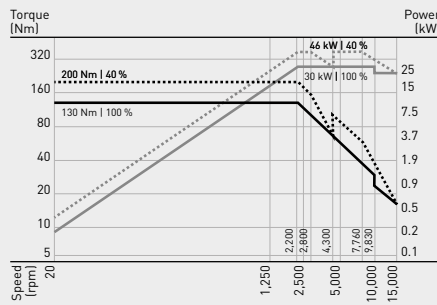

speedMASTER-spindle SK40/HSK-A63*

20,000 rpm / 35 kW / 130 Nm

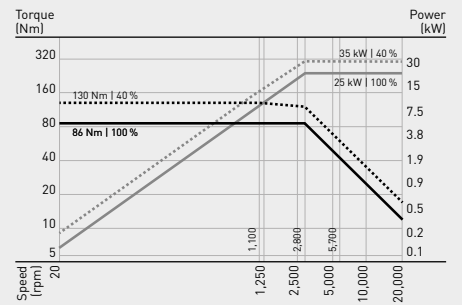

* Optional

DMU 50

Floor Plans

DMU 50

Front view with 30 tools (mm)

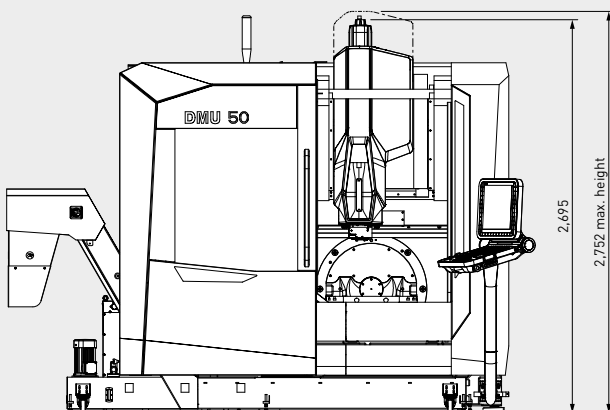

Plan view with 30 tools (mm)

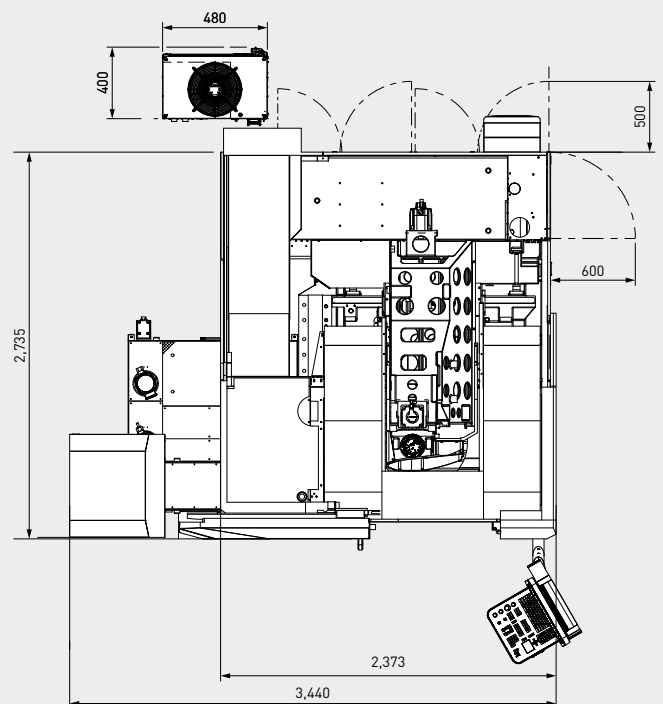

Technical Data

		DMU 50
Working area		
Travels X/Y/Z	mm	650/520/475
Main drive (standard)		
Speed range	rpm	20 – 15,000
Drive power (40/100% DC)	kW	21/16
Torque (40/100% DC)	Nm	111/85
Main drive (optional)		
Speed range	rpm	20 – 15,000
Drive power (40/100% DC)	kW	46/30
Torque (40/100% DC)	Nm	200/130
Main drive (optional)		
Speed range	rpm	20 – 20,000
Drive power (40/100% DC)	kW	35/25
Torque (40/100% DC)	Nm	130/86
Feed		
Rapid traverse X/Y/Z	m/min	42
Maximum thrust force X/Y/Z	kN	4.8
Swivelling rotary table		
Clamping area	mm	ø 630 × 500
B-/C-axis speed	rpm	30*
Maximum load	kg	300
Swivel range	Degrees	-35/+110
Tool magazine with double gripper		
Storage positions	Number	30/60**/120**
Maximum tool length	mm	300
Maximum tool diameter	mm	80/130
Tool weight max.	kg	8
Machine weight / connected values		
Weight	kg	7,480
Power	kW	28
Maximum current rating	A	40
Options		
Laser tool measurement; tool magazine 60/120 pockets; oil mist separator; coolant/air blast switch; air blast through spindle center; coolant gun; chip conveyor; internal coolant supply up to 40 bar		
Control		
ERGOline Control with a 21.5" multi-touch screen, CELOS and SIEMENS 840D solutionline		•
ERGOline Control with a 21.5" multi-touch screen, CELOS and HEIDENHAIN TNC 640		•
ERGOline Control with a 21.5" multi-touch screen, CELOS and FANUC MAPPS IVS ***		•
ERGOline Control with a 19.5" screen and HEIDENHAIN TNC 640		•



DMG MORI Service – fast and reliable!

“Our service commitment will meet your expectations with the highest quality of service!”

Available for you around the clock:

service-hotline.dmgmori.com 

Top quality at fair prices. **It's a promise!**



Spare Parts: 96 % global availability



Spindle Service with Fair Price Guarantee



Training: Professional training at highest standards



Service Products: Our protective shield for your DMG MORI machine

For further information please contact your local DMG MORI office.