

FMA/FMAC

スリワリフライス70径(56枚刃) ノンコート/OK-Cコート
Screw Slotting Cutters 70Dia. (56NT) non coat / OK-C coat

FMB/FMBC

スリワリフライス70径(72枚刃) ノンコート/OK-Cコート
Screw Slotting Cutters 70Dia. (72NT) non coat / OK-C coat

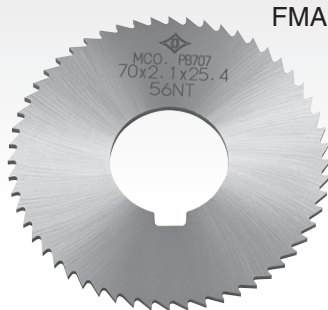

56枚刃
(56NT)

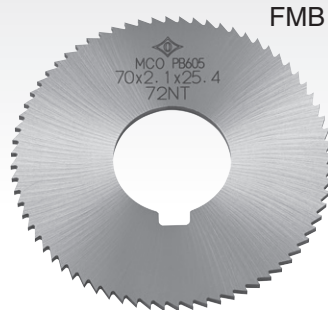

72枚刃
(72NT)

●溝入れ加工用
For slitting process

製品略号 Product code	表面処理 Surface Treatment	切削条件 Cutting Conditions
FMA		
FMAC		
FMB		
FMBC		

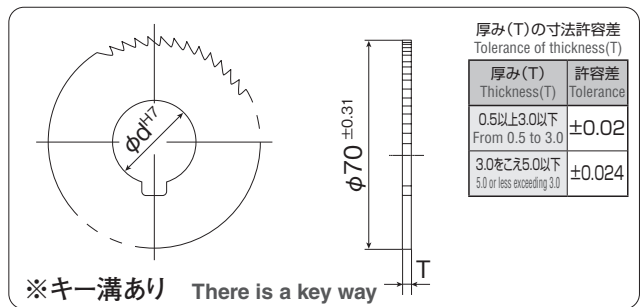

A = 56枚刃				B = 72枚刃				寸法 Size		
FMA ノンコート non coat	FMAC OK-Cコート OK-C coat	FMB ノンコート non coat	FMBC OK-Cコート OK-C coat	刃径 D	厚み T	穴径 d				
品番 Product No.	標準価格 Standard price ¥	品番 Product No.	標準価格 Standard price ¥	品番 Product No.	標準価格 Standard price ¥	品番 Product No.	標準価格 Standard price ¥			
FMA005	3,800	FMAC005	5,200	FMB005	3,800	FMBC005	5,200	70	0.5	25.4
FMA006	3,500	FMAC006	5,000	FMB006	3,500	FMBC006	5,000	70	0.6	25.4
FMA007	3,400	FMAC007	4,800	FMB007	3,400	FMBC007	4,800	70	0.7	25.4
FMA008	3,400	FMAC008	4,800	FMB008	3,400	FMBC008	4,800	70	0.8	25.4
FMA009	3,400	FMAC009	4,800	FMB009	3,400	FMBC009	4,800	70	0.9	25.4
FMA010	3,300	FMAC010	4,600	FMB010	3,300	FMBC010	4,600	70	1.0	25.4
FMA011	3,400	FMAC011	4,800	FMB011	3,400	FMBC011	4,800	70	1.1	25.4
FMA012	3,400	FMAC012	4,800	FMB012	3,400	FMBC012	4,800	70	1.2	25.4
FMA013	3,400	FMAC013	4,800	FMB013	3,400	FMBC013	4,800	70	1.3	25.4
FMA014	3,600	FMAC014	5,000	FMB014	3,600	FMBC014	5,000	70	1.4	25.4
FMA015	3,600	FMAC015	5,000	FMB015	3,600	FMBC015	5,000	70	1.5	25.4
FMA016	3,700	FMAC016	5,300	FMB016	3,700	FMBC016	5,300	70	1.6	25.4
FMA017	3,700	FMAC017	5,300	FMB017	3,700	FMBC017	5,300	70	1.7	25.4
FMA018	3,800	FMAC018	5,600	FMB018	3,800	FMBC018	5,600	70	1.8	25.4
FMA019	3,800	FMAC019	5,600	FMB019	3,800	FMBC019	5,600	70	1.9	25.4
FMA020	3,800	FMAC020	5,600	FMB020	3,800	FMBC020	5,600	70	2.0	25.4
FMA021	3,800	FMAC021	5,600	FMB021	3,800	FMBC021	5,600	70	2.1	25.4
FMA022	3,800	FMAC022	5,600	FMB022	3,800	FMBC022	5,600	70	2.2	25.4
FMA023	4,200	FMAC023	5,800	FMB023	4,200	FMBC023	5,800	70	2.3	25.4
FMA024	4,200	FMAC024	5,800	FMB024	4,200	FMBC024	5,800	70	2.4	25.4
FMA025	4,200	FMAC025	5,800	FMB025	4,200	FMBC025	5,800	70	2.5	25.4
FMA026	4,200	FMAC026	5,800	FMB026	4,200	FMBC026	5,800	70	2.6	25.4
FMA027	4,300	FMAC027	6,000	FMB027	4,300	FMBC027	6,000	70	2.7	25.4
FMA028	4,300	FMAC028	6,000	FMB028	4,300	FMBC028	6,000	70	2.8	25.4
FMA029	4,300	FMAC029	6,000	FMB029	4,300	FMBC029	6,000	70	2.9	25.4

スリワリフライスの側面振れ公差

Axial run-out tolerance of Screw Slotting Cutters

(単位 unit : mm)

外径(D) の区分 Dia. (mm)	側面の振れ Axial run-out						
	厚み(T)の区分 Thickness(T)						
	0.4以下 0.4 or less	0.4をこえ0.6以下 0.6 or less exceeding 0.4	0.6をこえ1.0以下 1.0 or less exceeding 0.6	1.0をこえ1.6以下 1.6 or less exceeding 1.0	1.6をこえ2.5以下 2.5 or less exceeding 1.6	2.5をこえ4.0以下 4.0 or less exceeding 2.5	4.0をこえ5.0以下 5.0 or less exceeding 4.0
45	0.16	0.12	0.1	0.08	0.06	0.05	—
70	—	0.16	0.12	0.1	0.08	0.06	0.05

- リーマ
- エンドミル
- ドリル
- 面取り/
座ぐり
- メタルソー
- カッター

A = 56枚刃				B = 72枚刃				寸法 Size		
FMA ノンコート non coat	FMAC OK-Cコート OK-C coat	FMB ノンコート non coat	FMBC OK-Cコート OK-C coat	品番 Product No.	標準価格 Standard price ¥	品番 Product No.	標準価格 Standard price ¥			
FMA030	FMAC030	FMB030	FMBC030					70	3.0	25.4
FMA031	FMAC031	FMB031	FMBC031	70	3.1	25.4				
FMA032	FMAC032	FMB032	FMBC032	70	3.2	25.4				
FMA033	FMAC033	FMB033	FMBC033	70	3.3	25.4				
FMA034	FMAC034	FMB034	FMBC034	70	3.4	25.4				
FMA035	FMAC035	FMB035	FMBC035	70	3.5	25.4				
FMA036	FMAC036	FMB036	FMBC036	70	3.6	25.4				
FMA037	FMAC037	FMB037	FMBC037	70	3.7	25.4				
FMA038	FMAC038	FMB038	FMBC038	70	3.8	25.4				
FMA039	FMAC039	FMB039	FMBC039	70	3.9	25.4				
FMA040	FMAC040	FMB040	FMBC040	70	4.0	25.4				
FMA041	FMAC041	FMB041	FMBC041	70	4.1	25.4				
FMA042	FMAC042	FMB042	FMBC042	70	4.2	25.4				
FMA043	FMAC043	FMB043	FMBC043	70	4.3	25.4				
FMA044	FMAC044	FMB044	FMBC044	70	4.4	25.4				
FMA045	FMAC045	FMB045	FMBC045	70	4.5	25.4				
FMA046	FMAC046	FMB046	FMBC046	70	4.6	25.4				
FMA047	FMAC047	FMB047	FMBC047	70	4.7	25.4				
FMA048	FMAC048	FMB048	FMBC048	70	4.8	25.4				
FMA049	FMAC049	FMB049	FMBC049	70	4.9	25.4				
FMA050	FMAC050	FMB050	FMBC050	70	5.0	25.4				

- 切断用
メタルソー
- 強力型
メタルソー
- メタルソー
- スリワリフライス