

Micrometer

The origin of Mitutoyo's trustworthy brand of small tool instruments

High-Accuracy Digimatic Micrometer SERIES 293

MeasurLink[®] ENABLED
Data Management Software by Mitutoyo

- Enabling 0.1 μm resolution measurement, this micrometer is ideal for customers who need to make highly accurate measurements with a hand-held tool.
- The High-Accuracy Digimatic Micrometer utilizes Mitutoyo's innovative 0.1 μm resolution ABS (absolute) rotary sensor*¹ and high-accuracy screw machining technology to reduce the instrumental error to $\pm 0.5 \mu\text{m}$, delivering higher accuracy without sacrificing operability.
*1 Patent pending in Japan, the United States of America, the European Union, and China.
- A highly rigid frame and high-performance constant-force mechanism*² enable more stable measurement, while the clicks emitted while the workpiece is being measured assure the operator that measurement is proceeding normally.
*2 Patent pending in Japan, the United States of America, the European Union, and China.
- Body heat transferred to the instrument is reduced by a (removable) heat shield, minimizing the error caused by thermal expansion of the frame when performing handheld measurements.

- The ABS (absolute) rotary sensor also eliminates the need to perform origin setting each time the power is turned on, letting you start measuring straight away. With no possibility of overspeed errors, the High-Accuracy Digimatic Micrometer also delivers a higher level of reliability.
- The High-Accuracy Digimatic Micrometer has a range of features to enable flexible measurement including switchable resolution (0.0001 mm/0.0005 mm), function lock and preset.
- Carbide-tipped measuring faces

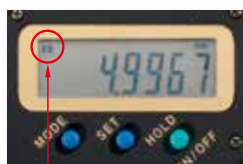

Function lock



293-100-10

MeasurLink[®] ENABLED

Data Management Software by Mitutoyo



Products equipped with the measurement data output function can be connected to the measurement data network system MeasurLink (refer to page A-5 for details).

An inspection certificate is supplied as standard. Refer to page U-11 for details.

ABSOLUTE[™]

Technical Data

Measuring force: 7 to 9 N
Power supply: Lithium battery (CR2032) × 1
Battery life: Approx. two years when used under normal conditions

Functions

Preset (ABS measurement system):

The measurement origin can be preset to any value within the display range for convenience in measuring.

Zero-setting (INC measurement system):

The display can be zeroed at any position of the spindle, making comparison measurement easier. Returning to the absolute-measurement mode is easily accomplished.

Hold:

The displayed value is held while the spindle is withdrawn and the micrometer moved so that the display can be read at the operator's convenience. After cancelling the hold, the instrument returns to the previous measuring mode (absolute or incremental).

Resolution switching:

The resolution of the display can be switched. If 0.1 μm measurement is not required, the resolution can be switched to 0.5 μm .

Function lock:

Functions such as preset or zero-set can be locked to avoid inadvertently changing the origin position.

On/off:

The power can be turned off after measurement is complete. Even after the power is turned off, the origin or last zero-set position remains in the memory.

Auto power off:

Even if the power is left on, the power turns off automatically if the micrometer is not used within a 20-minute period.

Measurement data output:

Measurement data can be output, allowing easy incorporation of this instrument into a statistical process control or measurement system.

Error alarm:

In the unlikely event of a display overflow or calculation error, an error message is displayed and measurement stops. Measurement cannot continue until the error is corrected.

Also, if the battery voltage drops below a certain point, the battery indicator will turn on before measurement becomes impossible, warning the user that the battery needs to be replaced.

Standard Accessories

Heat shield (**04AAB969A: 293-100-10**
04AAB969B: 293-130-10) × 1

Lithium battery CR2032 (1 pc.),
for initial operational checks (standard accessory)

Spanner (**200877**) × 1

Screwdriver (**04AAB985**) × 1

Cleaning paper for measuring faces

Inspection certificate



With heat shield attached

Heat shield



Optional Accessories

Connecting cables with output switch

1 m: **05CZA662**

2 m: **05CZA663**

USB Input Tool Direct

USB-ITN-B (2 m): 06AFM380B

Connecting cables for **U-WAVE-T**

160 mm: **02AZD790B**

For foot switch: **02AZE140B**

Refer to page B-68 for details.

Cleaning paper for measuring faces (1,000 sheet): **04AZB581**



Recommended micrometer stand: **MS-RB (156-101-10)**



DIMENSIONS

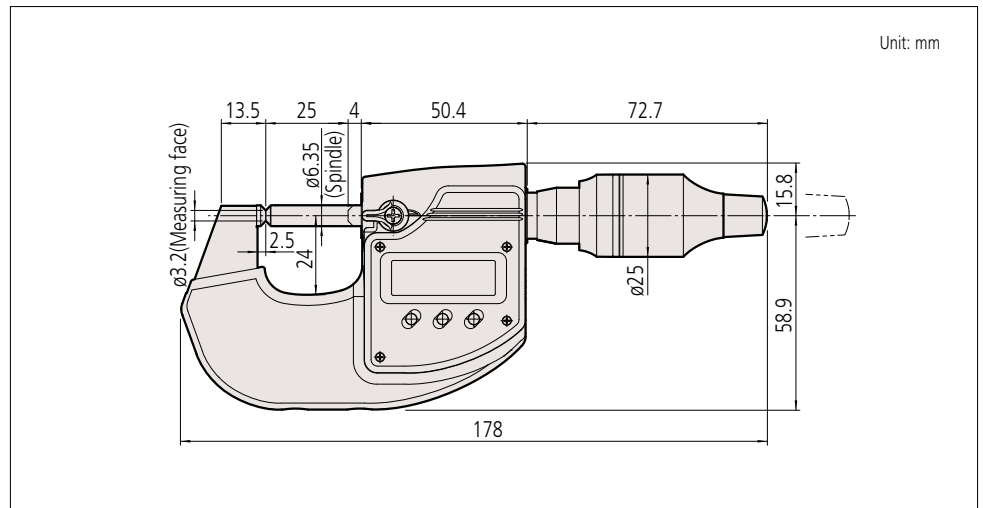

SPECIFICATIONS

Metric					
Order No.	Range (mm)	Resolution (mm)	Accuracy* (μm)	Anvil/spindle faces (mm)	Mass (g)
293-100-10	0 - 25	0.0001/0.0005 (switchable)	±0.5	ø3.2	400

* Excluding quantizing error of ±1 count

Inch / Metric					
Order No.	Range (in)	Resolution	Accuracy* (in)	Anvil/spindle faces (mm)	Mass (g)
293-130-10	0 - 1	0.000005/0.00002 in 0.0001/0.0005 mm (switchable)	0.00002	ø3.2	400

* Excluding quantizing error of ±1 count