

Technical Data

- Measuring face
Material: Carbide
Hardness: 90 HRA or more
Lapped
- Scale finishing:
Satin-chrome plated

Micrometer Heads SERIES 152 — Quick Spindle Feed of 1 mm/rev

- Micrometer head with 1 mm spindle pitch enables quick feeding and positioning.
- The larger screw thread also provides greater load-bearing capacity than does a standard head.

DIMENSIONS

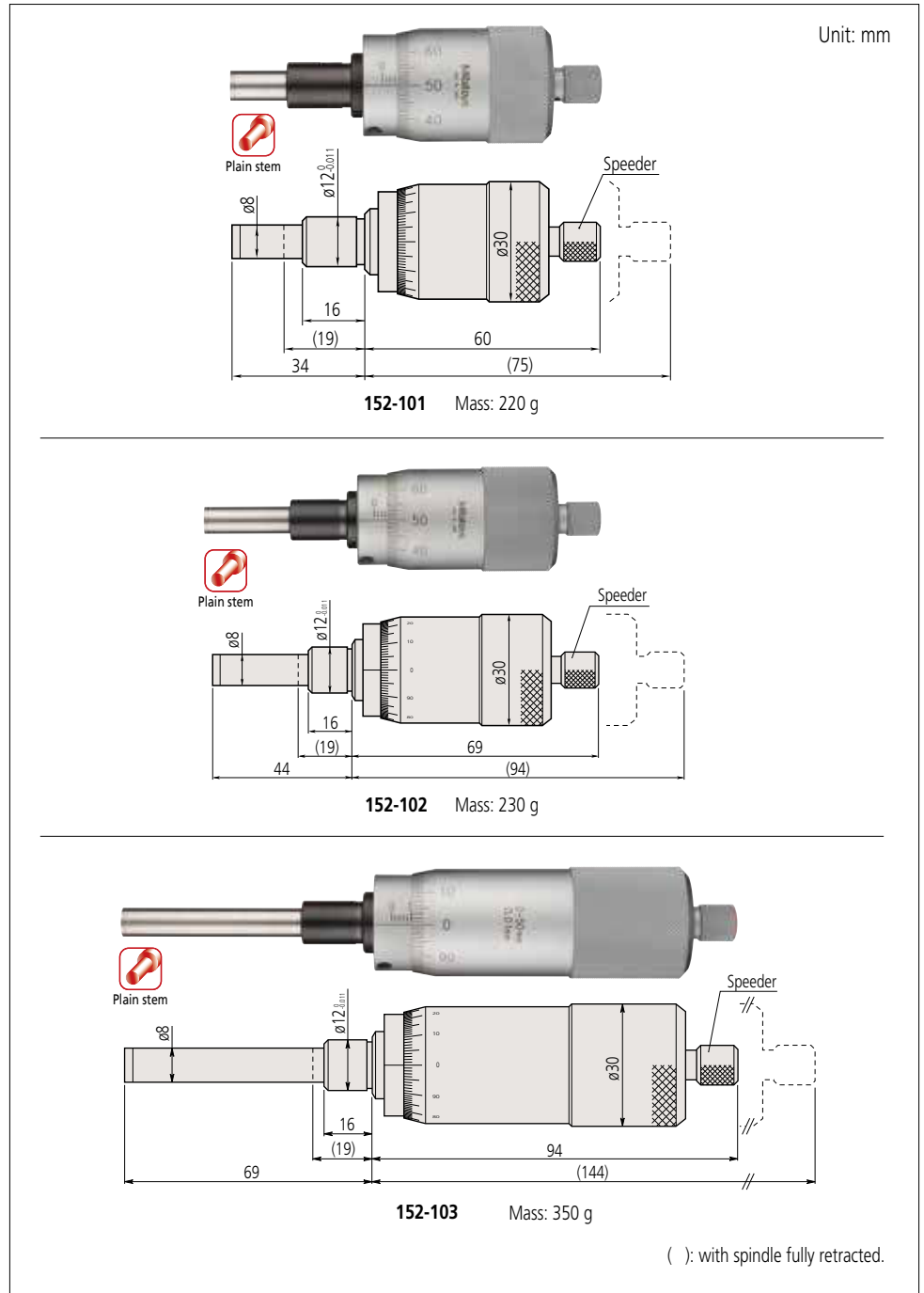

SPECIFICATIONS

Metric							
Order No.	Stroke (mm)	Graduation (mm)	Accuracy (μm)	Stem dia. (mm)	Stem	Spindle end	Spindle pitch (mm)
152-101	15	0.01	±2	12	Plain	Flat (carbide tip)	1
152-102	25		±4				
152-103	50		±4				