

Calipers

An industry standard measuring tool

ABSOLUTE Inside Caliper SERIES 573, 536 — Knife-edge/Inside Groove/Point Jaw Type

MeasurLink ENABLED
Data Management Software by Mitutoyo

- Specially designed for inside measurements in hard-to-reach places.
- Digimatic models are IP67 Absolute type. No need to reset the origin after switching on. (Refer to page D-8 for a description of Absolute measurement.)
- Allows integration into statistical process control and measurement systems for models with measurement data output connector. Refer to page A-3.
- It is necessary for measurement values of **573-645-20** and **573-646-20** to add the correction value to the displayed value. However, the featured offset function enables direct reading of the correction value displayed by pressing the OFFSET switch.

Knife-edge type

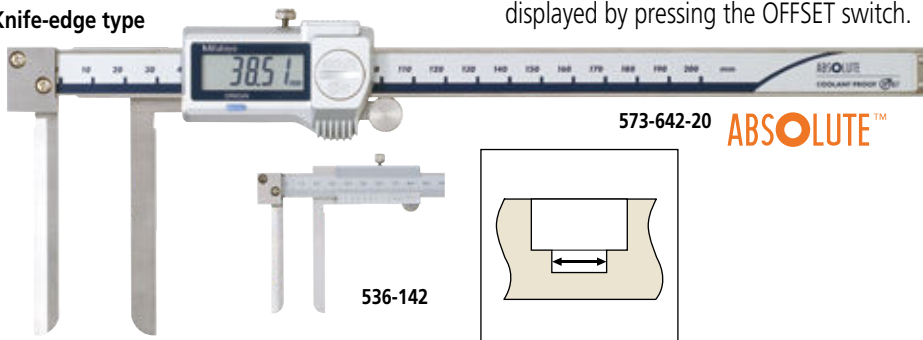

Inside groove type

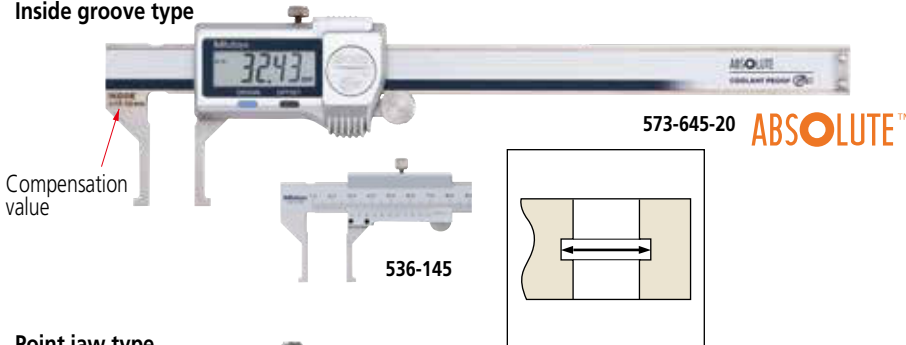

Point jaw type

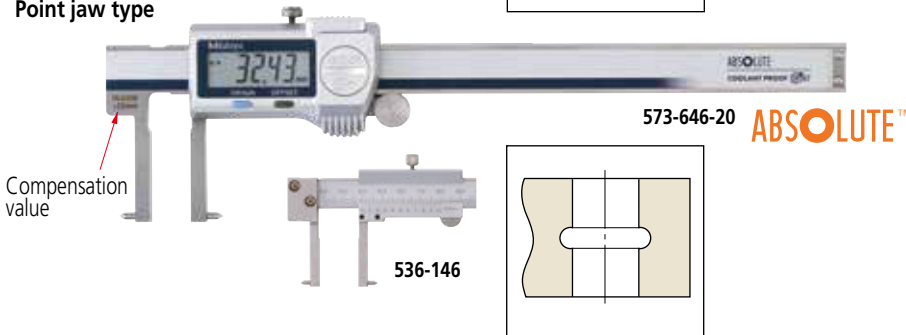

MeasurLink ENABLED
Data Management Software by Mitutoyo

Products equipped with the measurement data output function can be connected to the measurement data network system MeasurLink (refer to page A-5 for details).



Technical Data

- Accuracy: Refer to the list of specifications. (excluding quantizing error for Digimatic models)
- Resolution*1: 0.01 mm or 0.00005 in/0.01 mm
- Graduation*2: 0.05 mm
- Display*1: LCD
- Scale type*1: ABSOLUTE electromagnetic induction linear encoder
- Max. response speed*1: Unlimited
- Battery: SR44 (1 pc), **938882**, for initial operational checks (standard accessory)
- Battery life*1: Approx. 5 years under normal use
- Dust/Water protection level*1: IP67 (IEC 60529)*3
- *1 Digimatic models
- *2 Analog models
- *3 Rustproofing shall be applied after use if caliper was in contact with coolant.

Optional Accessories for Digimatic Models

- For details, refer to page D-38.
- Connecting cables for **IT/DP/MUX**
 - **05CZA624**: SPC cable with data button (1 m)
 - **05CZA625**: SPC cable with data button (2 m)
 - USB Input Tool Direct
 - **06AFM380A**: SPC cable for **USB-ITN-A** (2 m)
 - Connecting cables for **U-WAVE-T**
 - **02AZD790A**: SPC cable with data button (160 mm)
 - **02AZE140A**: SPC cable for foot switch

Wireless Data Output U-WAVE™

- **U-WAVE-TC: 264-620** (IP67 type)
 - **264-621** (Buzzer type)
 - Connecting unit for **U-WAVE-TC: 02AZF310** (IP67 type)
- Note: IP67 model is water/dust-proofed suitable for the factory floor.
Buzzer type is not water/dust-proofed.
Refer to page A-15 for details.
Note: cannot be used with **573-642-20**, **573-643-20** and **573-742-20**

SPECIFICATIONS

Metric	Digimatic model		
Order No.	Range (mm)	Accuracy (mm)	Remarks
573-642-20	10 - 200	±0.05	Knife-edge type, Measurable min.
573-643-20 *1	10 - 200	±0.05	Knife-edge type, Measurable min.
573-645-20 *2	10.1 - 160	±0.05	Inside groove type, Measurable min.
573-647-20 *1	10.1 - 160	±0.05	Inside groove type, Measurable min.
573-646-20 *2	20.1 - 170	±0.05	Point jaw type, Measurable min.
573-648-20 *1	20.1 - 170	±0.05	Point jaw type, Measurable min.

*1 Without thumb roller

*2 Includes the offsetting function, which indicates the actual measurement value.

Metric	Analog model		
Order No.	Range (mm)	Accuracy (mm)	Remarks
536-142	10.1 - 200	±0.12	Knife-edge type, Measurable min.
536-145	10.1 - 150	±0.05	Inside groove type, Measurable min.
536-146	20.1 - 150	±0.05	Point jaw type, Measurable min.
536-147	30.1 - 300	±0.08	Point jaw type, Measurable min.
536-148	70.1 - 450	±0.10	Point jaw type, Measurable min.
536-149	70.1 - 600	±0.12	Point jaw type, Measurable min.

Inch / Metric	Digimatic model		
Order No.	Range (in)	Accuracy (in)	Remarks
573-742-20	0.4 - 8	±0.002	Knife-edge type, Measurable min.
573-745-20 *2	0.404 - 6.4	±0.002	Inside groove type, Measurable min.
573-746-20 *2	0.804 - 6.8	±0.002	Point jaw type, Measurable min.

*2 Includes the offsetting function, which indicates the actual measurement value.

DIMENSIONS

Unit: mm

Knife-edge type: 536-142

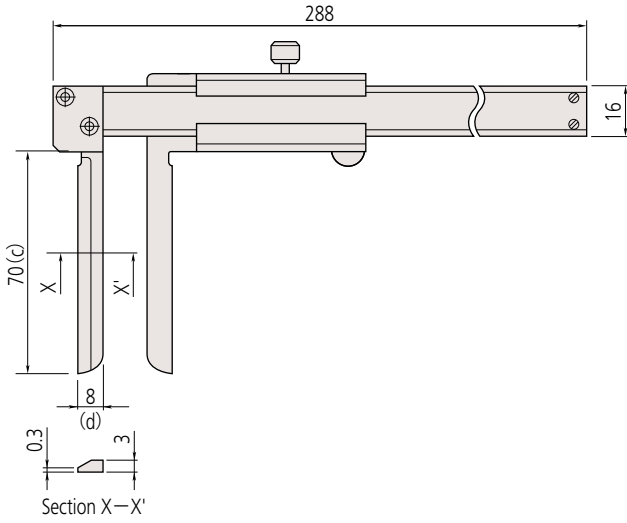

Knife-edge type: 573-642-20, 573-643-20, 573-742-20

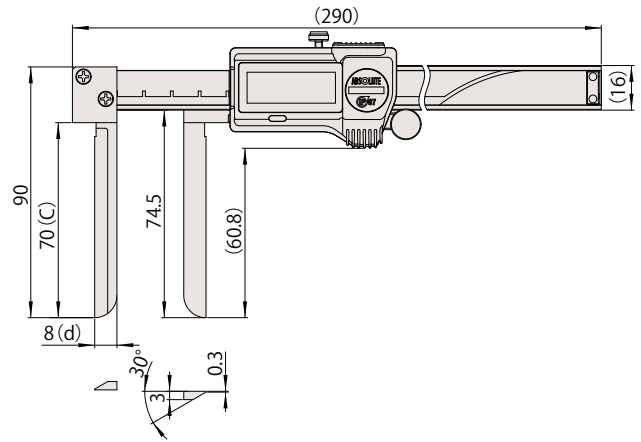

Inside groove type: 536-145

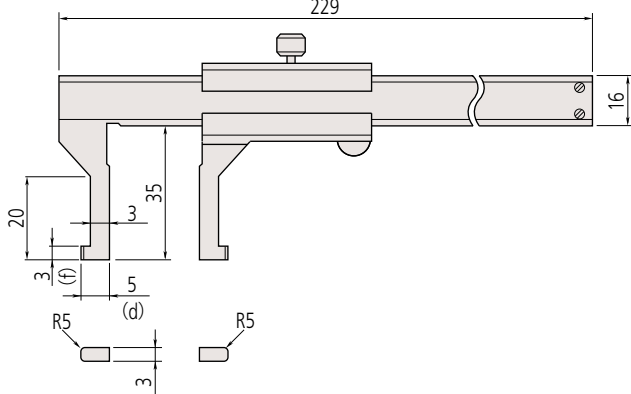

Inside groove type: 573-645-20, 573-647-20, 573-745-20

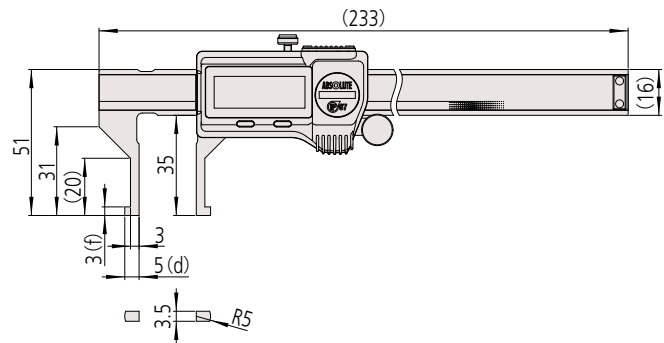

Point jaw type: 536-146, 147, 148, 149

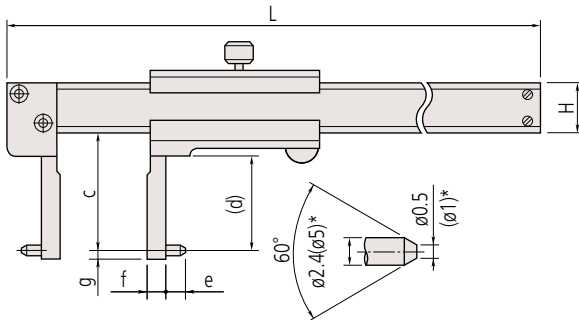

Point jaw type: 573-646-20, 573-648-20, 573-746-20

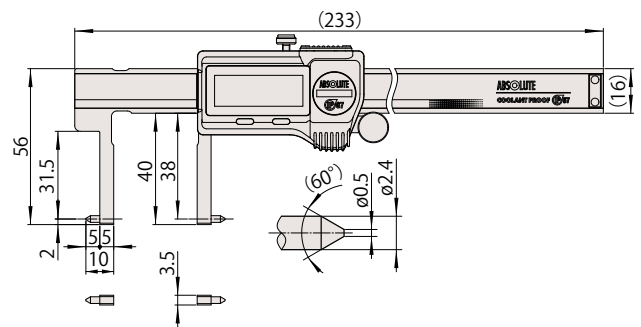

*Applies to 536-148 or 149

Range (mm)	c	d	e	f	g	H	L
150	38	31	5	5	2	16	229
300	98	89	5	10	2	20	403
450	145	136	10	25	5	25	610
600	145	136	10	25	5	25	750