

# Calipers

An industry standard measuring tool

## ABSOLUTE Snap Caliper SERIES 573

**MeasurLink** ENABLED

Data Management Software by Mitutoyo

- An ABSOLUTE electromagnetic induction linear encoder system is incorporated.
- Snap mechanism allows continuous and easy measurement without moving the slider by using the lever.
- The ABSOLUTE Digimatic snap caliper features a spring-loaded mechanism to allow quick and efficient GO/NO-GO inspection for mass production parts.
- Allows step measurement
- Displacement of snap part is 2 mm.
- Measuring force: 7 N to 14 N
- Absolute type. (Refer to page D-8 for a description of Absolute measurement.)
- Allows integration into statistical process control and measurement systems for models with measurement data output connector. Refer to page A-3.

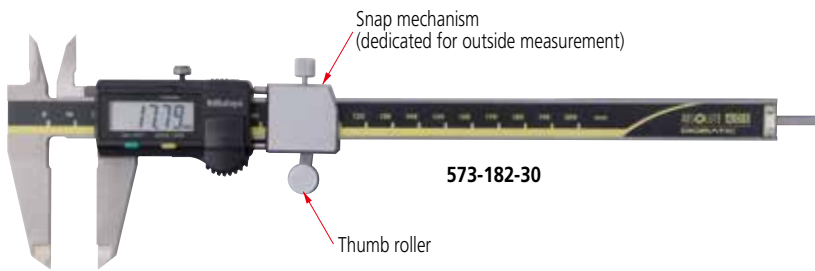

## SPECIFICATIONS

Metric			Inch / Metric		
Order No.	Range (mm)	Accuracy (mm)*	Order No.	Range (in)	Accuracy (in)*
573-181-30	0 - 100	±0.02	573-281-30	0 - 4	±0.001
573-182-30	0 - 150	±0.02	573-282-30	0 - 6	±0.001

\* Excluding quantizing error.  
Note: Dedicated for outside measurement (depth bar is not fitted).

## DIMENSIONS

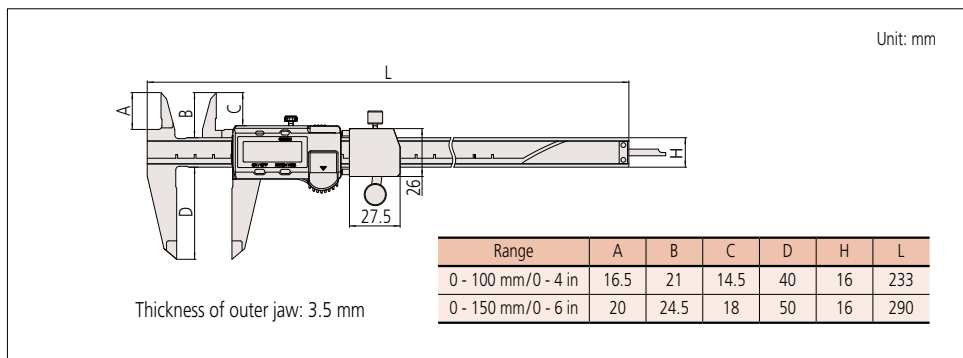

Products equipped with the measurement data output function can be connected to the measurement data network system MeasurLink (refer to page A-5 for details).

**ABSOLUTE**™

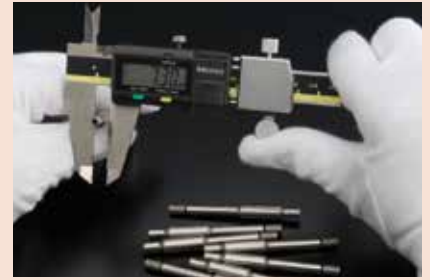

## Technical Data

- Accuracy: Refer to the list of specifications. (excluding quantizing error)
- Resolution: 0.01 mm or 0.0005 in/0.01 mm
- Repeatability: 0.01 mm
- Display: LCD
- Scale type: ABSOLUTE electromagnetic inductive linear encoder
- Jaw retraction: 2 mm
- Max. response speed: Unlimited
- Battery: SR44 (1 pc), **938882**, for initial operational checks (standard accessory)
- Battery life: Approx. 3.5 years under normal use

## Optional Accessories

For details, refer to page D-38.

- **959143**: Data hold unit
- Connecting cables for **IT / DP / MUX**
- **959149**: SPC cable with data button (1 m)
- **959150**: SPC cable with data button (2 m)
- USB Input Tool Direct
- **06AFM380C**: SPC cable for **USB-ITN-C** (2 m)
- Connecting cables for **U-WAVE-T**
- **02AZD790C**: SPC cable with data button (160 mm)
- **02AZE140C**: SPC cable for foot switch

## Wireless Data Output **U-WAVE**™

- **U-WAVE-TC: 264-620** (IP67 type)
  - **264-621** (Buzzer type)
  - Connecting unit for **U-WAVE-TC: 02AZF300** (Buzzer type)
- Note: IP67 model is water/dust-proofed suitable for the factory floor.  
Buzzer type is not water/dust-proofed.  
Refer to page A-15 for details.