

Inspection Instrument for Indicators i-Checker



For efficient in-house calibration

Dial Indicators

Digimatic Indicators

Bore Gages



Various types of indicators can be

Features

- Inspection can be performed 2.5 times faster compared to the previous model.
- This instrument achieves the highest accuracy in its class (Mitutoyo survey, February 2016) and, therefore, guarantees ultra-reliable inspection results.
- Digital indicators equipped with a data output function are checked very efficiently due to spindle positioning at the inspection points and recording of measurement results being under fully automatic control.
- Analog type indicators are inspected in semi-automatic mode with the pointer of the indicator being manually adjusted at each measuring point with automatic transfer of inspection results and movement to the next measuring point.
- The latest standard for lever-operated dial test indicators, ASME and DIN, are applied.
- Inspection standards to a customer's own specification can be implemented.

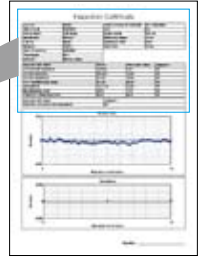

Inspection Certificate			
Order No.	01000	Name of Inspection Standard	ISO 15026:2010
Date of Issue	2024/01/15	Inspected	OK
Inspection Point	1st Stage	Inspection Method	DM
Manufacturer	Mitoyo	Measuring Range	0-100mm
Model No.	DI-100	Reference Point	0mm
Serial No.	100001	Use Point	100mm
Date of Expiration	2025/01/15		
Temperature	20°C		
Inspector	Mitoyo Japan		
Inspection Item Name	Normal	Permissible Value	Alignment
Any One With Measurement	0.002mm	0.005mm	OK
Any With Measurement	0.005mm	0.010mm	OK
Any Two Measurement	0.010mm	0.020mm	OK
Any Three Measurement	0.020mm	0.050mm	OK
Any Four Measurement	0.050mm	0.100mm	OK
Any Five Measurement	0.100mm	0.200mm	OK
Any Six Measurement	0.200mm	0.500mm	OK
Any Seven Measurement	0.500mm	1.000mm	OK
Any Eight Measurement	1.000mm	2.000mm	OK
Any Nine Measurement	2.000mm	5.000mm	OK
Any Ten Measurement	5.000mm	10.000mm	OK
Inspection Item Name		Alignment	
Inspection of Functional Appearance		OK	



Inspection using analog type indicator



Inspection using digital type indicator

Dial Test Indicators

Inspection Instrument for Indicators i-Checker

Linear Gages

Electronic Micrometers



inspected with a single tester.

- A laptop PC can be connected using a USB cable, which contributes to space-saving.



- All functions necessary for inspection are combined in the control box so that the operator need not rely on excessive eye movement to adjust the pointer.

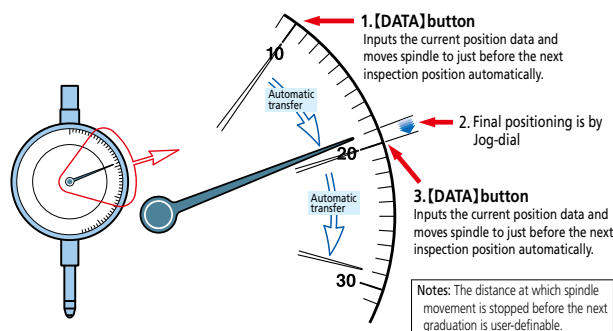

Optional Accessories and Applications

Applications for Bore Gage Accessory Set



Applications for bore gage measurement accessory set (type C)



Application for mounting bore gage accessory set (type C)
Order No. 02ASU161



i-Checker mountable bore gages

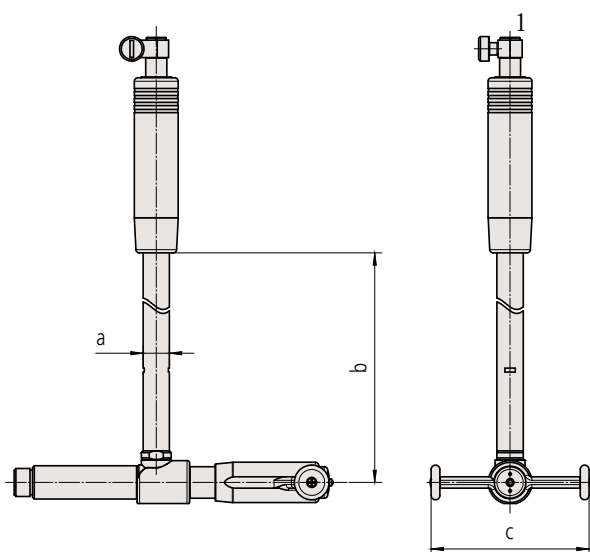

	Range (mm)
a	ø6 - ø18
b	50 or below
c	120 or below

List of components for bore gage accessory set (type C) Order No.02ASU161

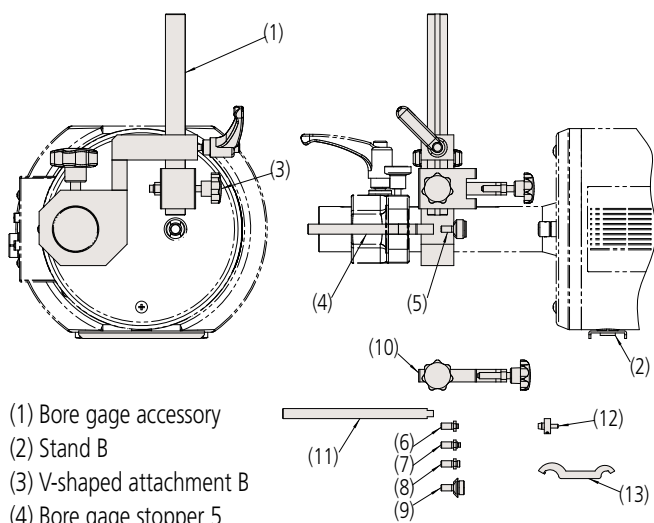

- (1) Bore gage accessory
- (2) Stand B
- (3) V-shaped attachment B
- (4) Bore gage stopper 5
- (5) Anvil (for calibration, M11 female)
- (6) Anvil (for calibration, M3.5 x 0.35 male)
- (7) Anvil (for calibration, M3.5 x 0.5 male)
- (8) Anvil (for calibration, M5 male)
- (9) Anvil (for calibration, M11 male)
- (10) V-shaped attachment C
- (11) Bore gage stopper 3
- (12) i-Checker's special contact point
- (13) Key wrench

Optional Accessories and Applications

Applications for Dial Test Indicator Accessory Set



Applications for dial test indicator accessory set (for horizontal type)



Applications for dial test indicator accessory set (for vertical type)



Dial test Indicator accessory set (for $\phi 6$ stem)
Order No.02ASK000

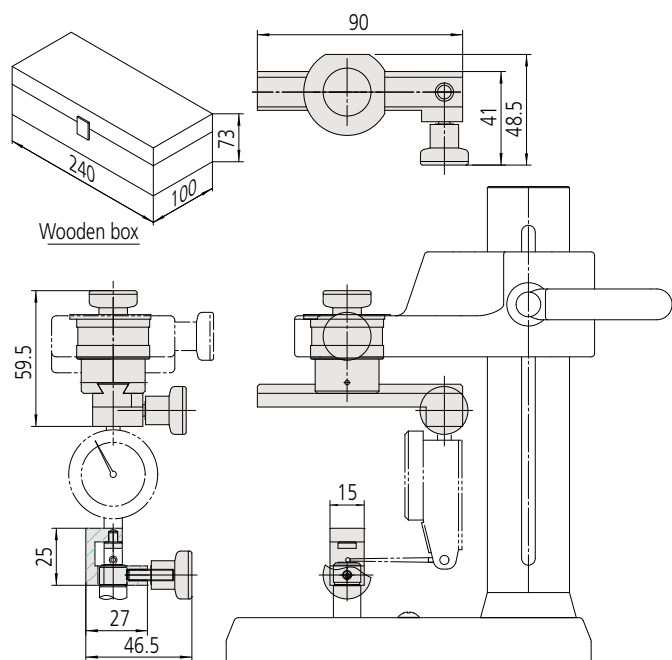

Optional accessories Attachments/Stem bush/Others/Connecting cables

Order No.	Item	Usage and remarks
Attachment		
02ASK000	Test indicator accessory set (for ø6mm stem)	For attachment of ø6 stem test indicator
02ASK180	Test indicator accessory set (for ø8mm stem)	For attachment of ø8 stem test indicator
02ASK370	Test indicator accessories set (for ø6 stem)	Holder to fix ø6 stem to 02ASK180
02ASK380	Test indicator accessories set (for ø8 stem)	Holder to fix ø8 stem to 02ASK000
902803	ø6 dovetail grooved stem	Stem to attach Mu-Checker with knurled clamp ring (lever head type) to test indicator accessory set (02ASK000)
902804	ø8 dovetail grooved stem	Stem to attach Mu-Checker with knurled clamp ring (lever head type) to test indicator accessory set (02ASK180)
02ASU161	Bore gage accessory set (type C)	Accessory set for holding grip type bore gage
Stem bush		
02ASK040	Stem bush ø6	
02ASJ856	Stem bush ø8	
02ASK150	Stem bush ø8, short	For attachment of cartridge head MCHP-341
02ASL150	Stem bush ø10	
02ASK050	Bush ø9.5 - ø15	For attachment of LGB2 fixing nut type with stem diameter ø9.5 Stem bush (ø15mm) is required separately.
02ASK060	Stem bush ø12	
02ASK070	Stem bush ø15	
02ASK080	Stem bush ø20	
02ASK710	Stem bush ø28	
02ASK090	Stem bush ø3/8 in	For attachment of indicator with stem diameter ø9.525mm
02ASK130	Wooden box for No. 02ASK130 stem bushes	Storage of 7 stem bushes and 1 bush (ø9.5 - ø15mm)
Others		
937179T	Foot switch	Used instead of [DATA] button in the operation box.
02ASK730	Observation mirror	
Connecting cables		
905338	Connecting cable (1m)*1	Used for connecting with Digimatic Indicators (ID-C, ID-S, ID-U, and IDU)
905409	Connecting cable (2m)*1	
936937	Connecting cable (1m)*1	(ID-F, ID-F, Digimatic power supply unit and between the testers)
965014	Connecting cable (2m)*1	
937387	Connecting cable (1m)*1	Used for connecting with Digimatic Indicators (IDC and IDA)
965013	Connecting cable (2m)*1	
965275	Digimatic power supply unit*2	Used for the Digimatic Indicators that require external power supply

*1 Use the cable described in the user's manual.

*2 Confirm the specification in the user's manual.

Required optional accessories Dedicated software (i-Pak specification)

• Supported OS

Windows10 (64bit)

• Supported Industrial Standards

ISO, JIS, JMAS, ANSI/ASME, DIN, VDI/VDE/DGQ, BS

• Basic inspection functions

- Creation of inspection standard conformed to the industrial standard
- Creation and edition of original inspection standard, by customizing the industrial standard
- Inspection of indicator using the inspection standard (inspection for accuracy and repeatability)
- Graphical display of measurement result
- Creation, edition, and printing of simplified inspection certificate

• Function

- Retry "measurement positioning"
- Re-measurement
- Data cancellation
- Change of speed for jog shuttle

• Input/Output specifications

- Digimatic data connector (rear side of i-Checker main unit)*3
- PC serial-data input port (RS-232C)
- Printing of simplified inspection certificates

*3 Automatic measurement requires the indicator's connecting cable.

Additionally some form of indicator, along with the normally connected accessory (the optional accessory for the indicator such as a Digimatic power-supply unit in an EF counter) will be required.

Supported indicators

- Dial Indicator
- Dial Test Indicator
- Mitutoyo Hicator
- Bore Gage
- Digimatic Indicator
- Linear Gage
- Electronic micrometer (Mu-Checker)

* It cannot inspect the indicator with accuracy that is higher than the main unit accuracy of the tester.

* Resolution of electronic micrometer (Mu-checker) is greater than 1µm (e.g. 1µm/5µm/10µm/50µm).

Supported Industrial Standards

	Dial Indicator	Dial Test Indicator	Hicator	Bore Gage	Digimatic Indicator	Linear Gage	Electronic micrometer
ISO	463-2006 R463-1965	9493-2010	—	—	—	—	—
JIS	B7503-2011 B7503-1997 B7503-1992	B7533-2015 B7533-1990	B7519-1994	B7515-1982	—	—	B7536-1982
JMAS	2001-1998 2001-1994 2003-1994	—	—	5009-1988	—	—	5003-1962
ANSI/ASME	B89.1.10M-2001 B89.1.10M-1987	B89.1.10M-2001 B89.1.10M-1987	—	—	B89.1.10M-2001	—	—
DIN	878-2006 878-1983	2270-1985	879-1983	—	—	—	—
VDI/VDE/DGQ	2618 Blatt11-1991	2618 Blatt11.3-2002 2618 Blatt20-1991	2618 Blatt21-1991	—	—	—	2618 Blatt26-1991
BS	907-1965	2795-1981	—	—	—	—	—
Mitutoyo Standard	—	—	—	—	✓	✓	—

Specifications

Order No.	170-402/170-403	
Measuring Range	100mm	
Resolution	0.01μm	
Accuracy (20°C)	vertical position	(0.1+0.4L/100) μm L = Arbitrary length (mm)
	lateral position	(0.15+0.6L/100) μm L = Arbitrary length (mm)
Feed speed	Maximum 10mm/s	
Drive method	Motor drive, semi-automatic, fully automatic (Fully automatic only for Indicator with SPC data output)	
Measuring Unit	Separate type Linear Encoder	
Thermal expansion coefficient of measurement mode	1.5×10 ⁻⁶ / K	
Measurement method	Semi-automatic measurement	
	Fully automatic measurement (only when using an indicator equipped with data output function) *1*2	
Mass	20kg	
Operating temperature range	20°C±0.5°C	

*1 Automatic measurement requires the indicator's connecting cable. Additionally some form of indicator, along with the normally connected accessory (the optional accessory for the indicator such as a Digimatic power-supply unit in an EF counter) will be required.

*2 The indicator measured via RS-232C has the capability to receive data from the main unit and output the counter value.

Standard accessories supplied Order No.170-402/170-403

Order No.	Item	QTY.
02AST250	Tester main unit	1
02AST780	Controller ICMC-2	1
02AST830	Control box	1
02ASU001	EXT. Signal Cable	1
02ASU002	EXT. Motor Cable	1
02ASU003A	EXT. USB2.0 Cable	1
02ASJ856	Stem bush 8mm, only for No.170-402	1
02ASK091	Stem bush 9.525mm (3/8 in), only for No.170-403	1
601614-2	Dust cover	1
99MBD063A	User's Manual (English)	1
—	Inspection certificate, Certification of calibration and Traceability chart (English)	1

Dimensions

Unit: mm

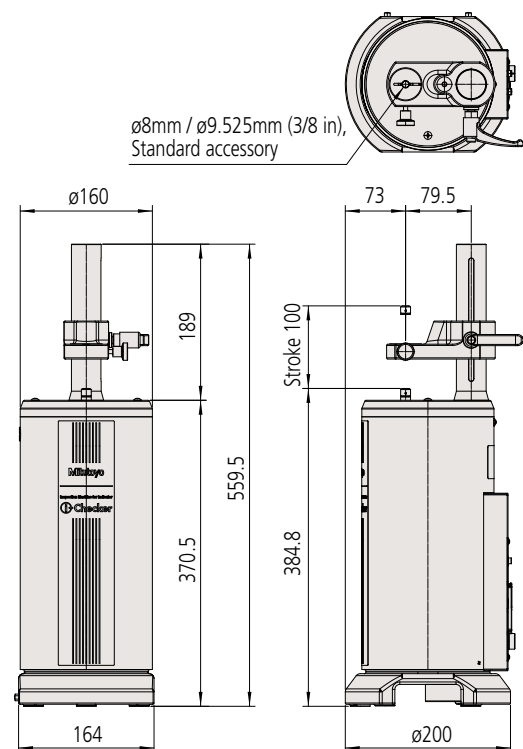



Whatever your challenges are, Mitutoyo supports you from start to finish.

Mitutoyo is not only a manufacturer of top quality measuring products but one that also offers qualified support for the lifetime of the equipment, backed up by comprehensive services that ensure your staff can make the very best use of the investment.

Apart from the basics of calibration and repair, Mitutoyo offers product and metrology training, as well as IT support for the sophisticated software used in modern measuring technology. We can also design, build, test and deliver bespoke measuring solutions and even, if deemed cost-effective, take your critical measurement challenges in-house on a sub-contract basis.



Find additional product literature and our product catalogue

<http://www.mitutoyo.co.jp/global.html>

Export permission by the Japanese government may be required for exporting our products according to the Foreign Exchange and Foreign Trade Law. Please consult our sales office near you before you export our products or you offer technical information to a nonresident.

Note: Product illustrations are without obligation. Product descriptions, in particular any and all technical specifications, are only binding when explicitly agreed upon.
MITUTOYO and MICAT are either registered trademarks or trademarks of Mitutoyo Corp. in Japan and/or other countries/regions. Other product, company and brand names mentioned herein are for identification purposes only and may be the trademarks of their respective holders.

Mitutoyo

Mitutoyo Corporation

20-1, Sakado 1-Chome,
Takatsu-ku, Kawasaki-shi,
Kanagawa 213-8533, Japan
T +81 (0) 44 813-8230
F +81 (0) 44 813-8231
<http://www.mitutoyo.co.jp>