

Standard Accessories

Spanner (301336), 1 pc.

Universal Micrometer SERIES 116 — Interchangeable Anvil Type

- Non-rotating spindle type which accepts seven forms of optional interchangeable anvil/spindle tip (flat, spline, spherical, point, knife-edge, disk, and blade) for a wide range of applications.
- Equipped with Ratchet Stop for constant measuring force.
- Interchangeable anvils/spindle tips are optional.



116-101-10

SPECIFICATIONS

Metric			
Order No.	Range (mm)	Graduation (mm)	Spindle feed error (μm)
116-101-10	0 - 25	0.01	3
116-102-10*1	25 - 50		

Inch			
Order No.	Range (in)	Graduation (in)	Spindle feed error (in)
116-105-10	0 - 1	0.001	0.00015
116-106-10*2	1 - 2		

*1 Provided with a plain setting standard (167-101) and a 60°-thread setting standard (167-261) for adjusting the minimum range point according to the application.

*2 Provided with a plain setting standard (167-141) and a 60°-thread setting standard (167-294) for adjusting the minimum range point according to the application.

Order No.	Description
116-801	Flat
116-802	Spline
116-803	Spherical
116-804	Point
116-805	Knife-edge
116-806	Disk
116-807	Blade
116-800	Anvils/spindle tips set (7 pairs) (116-801 - 116-807 Set)

Optional Accessories

- Interchangeable anvils/spindle tips are available in matching pairs.

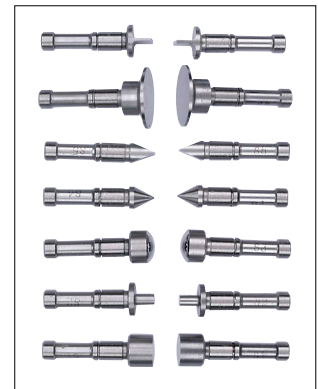
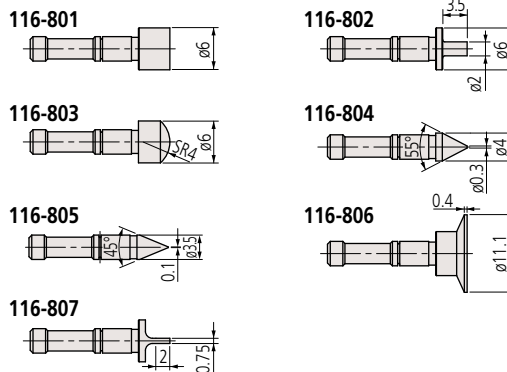

Order No.	Set Identifier Range of measurement
116-831	0.4 - 0.5 mm/64 - 48TPI
116-832	0.6 - 0.9 mm/44 - 28TPI
116-833	1 - 1.75 mm/24 - 14TPI
116-834	2 - 3 mm/13 - 9TPI
116-835	3.5 - 5 mm/8 - 5TPI
116-836	5.5 - 7 mm/4.5 - 3.5TPI
116-830	116-831 - 116-836 M (U) Set

Note: The shape differs from the interchangeable contact point of series 326 and 126.

- Thread-measuring interchangeable contact points are available in matching pairs.

