

Mid-size SCARA robot for precision machining, assembly, and material handling

- EtherCAT connectivity to the Omron NJ501-R controller and programming through the familiar IEC 61131-3 programming language or scripting (eV+)
- High repeatability suitable for material handling and precision assembly
- High payload for screw-driving tools
- Amplifier and controller built into the robot simplifies integration
- Choose the right robot for you application from two different types
- Reach 600 mm
- Maximum payload 5.5 kg
- Weight 41 kg



Specifications

Product name		eCobra			
		600 Standard		600 Pro	
		Standard	Cleanroom	Standard	Cleanroom
Part Number		RL4-1166000	RL4-1166010	RL4-2166000	RL4-2166010
Number of axes		4			
Mounting		table/floor			
Reach		600 mm			
Maximum Payload		5.5 kg			
Repeatability	XY	±0.017 mm			
	Z	±0.003 mm			
	Theta	±0.019°			
Joint Range	Joint 1	±105°			
	Joint 2	±157.5°			
	Joint 3	210 mm			
	Joint 4	±360°			
Inertia Moment (Max.)	Joint 4	450 kg-cm ²			
Joint Speeds	Joint 1	386°/s			
	Joint 2	720°/s			
	Joint 3	1100 mm/s			
	Joint 4	1200°/s			
Power Requirements		24 VDC: 6 A 200 to 240 VAC: 10 A, single-phase			
Protection		IP20			
Clean Class		---	Class 10	---	Class 10
Environment Requirements	Ambient Temperature	5 to 40°C			
	Humidity Range	5 to 90% (non-condensing)			
Weight		41 kg			
Basic configuration	Controller	ICS-ECAT			
	On-board I/O (Input/Output)	12/8, 4 Solenoid Output			
	Conveyor tracking input	No		2	
	RS-232C serial communications port	1			
	Programming environment	Sysmac Studio 64-bit			
	ACE Sight	Yes			
	ePLC Connect	No			
ePLC I/O	No			No	
Connectable controller		Omron NJ501-R Series			

*1. Adept cycle, in mm 25/305/25 (seconds, at 20°C ambient)

Dimensions

(Unit: mm)

eCobra 600

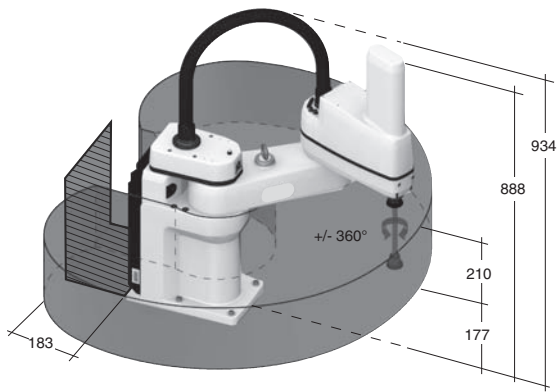

- Work Envelope: Radius 600 mm
Inner Limit: Radius 163 mm
Height: 210 mm
- ▨ Required clearance to open eAIB Chassis

Flange

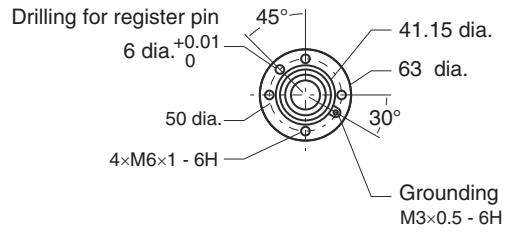

Footprint

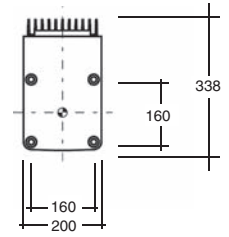

Front panel

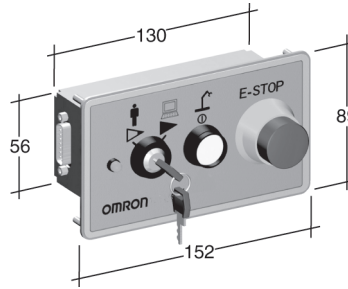

Robot Parts Code and Bundled Accessories

Type	eCobra	
	Standard	Cleanroom
Cleanroom		
eCobra 600 Standard	RL4-1166000	RL4-1166010
eCobra 600 Pro	RL4-2166000	RL4-2166010
Overview	Robot + iCS-ECAT	
Purpose	To be used in conjunction with NJ501-R controller, which can connect up to 8 robots via EtherCAT	
Bundled Accessories	<ul style="list-style-type: none"> • XSYSTEM cable with jumpers, and Ethernet Management port, 1,8 m/6ft (13323-100) • Front panel kit (90356-10358) 	