

# Mitutoyo

Mitutoyo Quality

## Microscopic Form Measurement System **UMAP Vision System**

VISION MEASURING SYSTEMS



# Microscopic Form Measurement System

## UMAP Vision System

The UMAP Vision System is an ultra-low-measuring-force probe that uses Mitutoyo's proprietary sensing technology.

With a lineup of styli ranging from a minimum diameter of 15  $\mu\text{m}$ , this product responds to the needs of our customers for microscopic dimension and form measurement.

### UMAP Vision System Features

- Stylus with a minimum diameter of 15  $\mu\text{m}$  makes contact measurements of microscopic areas possible.

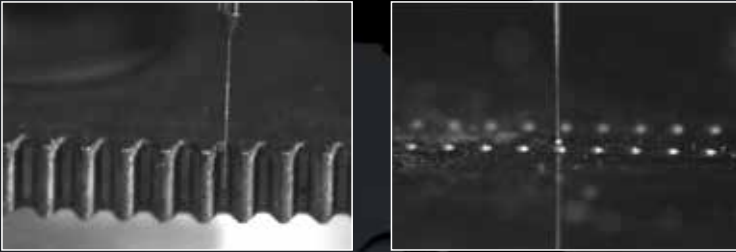

- Ultra low measuring force of a minimum 1  $\mu\text{N}$  (UMAP103) makes it possible to measure even workpieces that are easily deformed.
- Up to three types of UMAP styli, each of a different diameter can be used in combination. The user can install, remove, and replace styli.

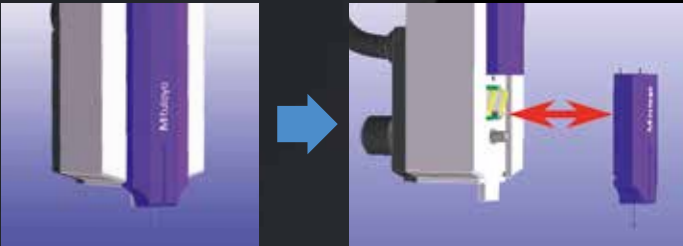

- This one unit can be used to perform contact measurements using UMAP mode and non-contact measurements using vision mode. Even for parts that are difficult to see, vision mode can be used to perform workpiece positioning, and then the UMAP mode can be used to perform aimed measurements.

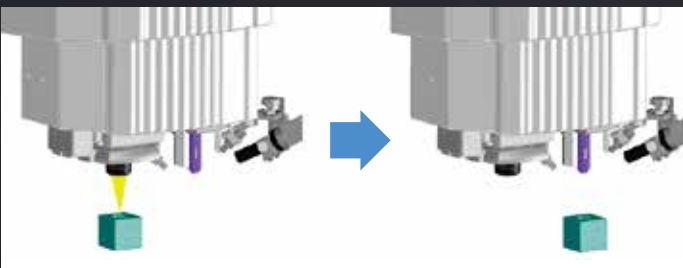

## Detection Principle

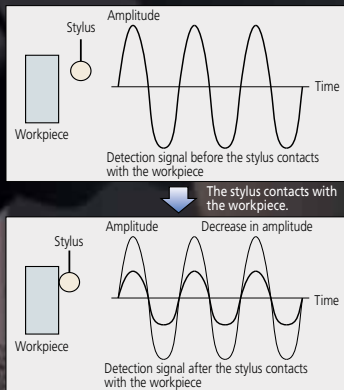

1. As shown in the figure to the left, the stylus maintains a micro-vibrating state when not in contact with the workpiece.
2. When the stylus comes into contact with the workpiece, the stylus vibration is restricted by the workpiece, which causes the vibration amplitude to decrease. A touch-trigger signal will be detected when the amplitude decreases past a certain level.
3. When the stylus moves away from the workpiece, the stylus vibration amplitude returns to the state that was present when the stylus was not in contact with the workpiece, which makes the stylus ready for use in performing the next measurement.

## UMAP Stylus Lineup

Five types of stylus modules that differ in stylus tip radius and shaft length are available. Up to three types of styli can be used in combination, which makes it possible to select the optimum stylus to match the workpiece to be measured.

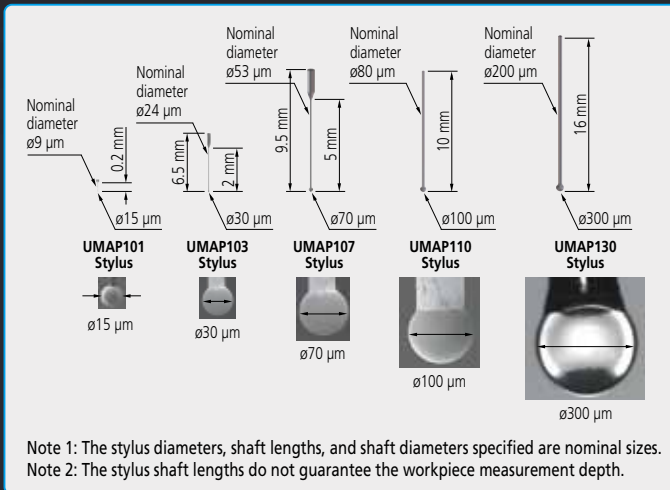

## UMAP Measurement Workpiece Examples

The following are examples of workpieces that can be measured with UMAP. UMAP provides a solution for microscopic dimension measurement and form evaluation in a wide variety of fields such as precise microscopic molds, micromachining pressed products, microscopic resin molded products, and EDM electrodes.

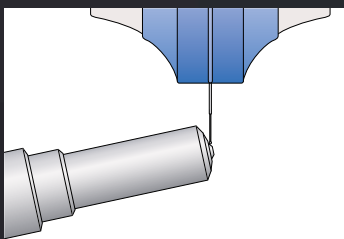

Form measurement of the hole of a fuel injection nozzle

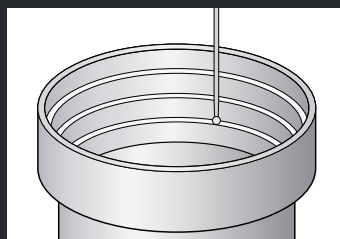

Form measurement of a lens tube



Measurement of microscopic gear tooth and tooth-form profile / tooth-alignment profile

# UMAP Vision System Specifications

## HYPER UMAP Vision System 302 TYPE2



- The application of high-performance objectives with high NA and low distortion and a new optical system provide the UMAP Vision System with excellent edge-detection capability.
- The standard length measuring system uses a low-expansion glass scale with a linear expansion coefficient of  $(0 \pm 0.02) \times 10^{-6} \text{K}$ , which keeps glass scale expansion/contraction due to temperature changes to the absolute minimum.

Model No.	HYPER UMAP Vision System 302 TYPE2		ULTRA UMAP Vision System 404 TYPE2	
Model	UVS2-H302P1L-D		UVS2-U404P1N-D	
Measuring range (XxYxZ)	300x200x200 mm		400x400x200 mm Effective measuring range on glass stage: 360x400x200 mm*1	
Effective measuring range (common between images and UMAP103)	185x200x175 mm		285x400x175 mm	
Observation unit*2	PPT 1X, 2X, 6X		PPT 1X, 2X, 6X	
Resolution	0.02 $\mu\text{m}$		0.01 $\mu\text{m}$	
Imaging Device	B&W CCD			
Illumination unit	Co-axial Light	White LED	Halogen	
	Transmitted Light	White LED	Halogen	
	PRL	White LED	Halogen	
Measuring accuracy*3	Vision	E <sub>ix</sub> , E <sub>iy</sub>	(0.8 + 2L/1000) $\mu\text{m}$	(0.25 + L/1000) $\mu\text{m}$
		E <sub>iz</sub> (50 mm stroke)*4	—	(1.0 + 2L/1000) $\mu\text{m}$
		E <sub>iz</sub> (full stroke)	(1.5 + 2L/1000) $\mu\text{m}$	(1.5 + 2L/1000) $\mu\text{m}$
		E <sub>zxy</sub>	(1.4 + 3L/1000) $\mu\text{m}$	(0.5 + 2L/1000) $\mu\text{m}$
	Optical condition for accuracy assurance	QV-HR2.5X or QV-SL2.5X + Middle magnification tube lens	QV-5X + Middle magnification tube lens	
UMAP	E <sub>ix</sub> , E <sub>iy</sub> (UMAP110)*5	(1.7 + 3L/1000) $\mu\text{m}$	(1.5 + 3L/1000) $\mu\text{m}$	
UMAP repeatability*3*6	UMAP101, 103, 107	$\sigma = 0.1 \mu\text{m}$	$\sigma = 0.08 \mu\text{m}$	
	UMAP110, 130	$\sigma = 0.15 \mu\text{m}$	$\sigma = 0.12 \mu\text{m}$	
Repeatability within screen*3	—		3 $\sigma = 0.2 \mu\text{m}$	
Operating temperature range	Ambient temperature	18 to 23 °C	19 to 23 °C	
	Temperature variation	0.5 °C/1 H and 1 °C/24 H		
Stage glass size	399x271 mm		493x551 mm	
Maximum stage loading*7	15 kg		40 kg	
Main unit external dimensions	859x951x1609 mm		1200x1735x1910 mm	
Main unit mass (including the sub-base)	370 kg		2160 kg	
Operating air pressure	0.4 MPa (requires a supply pressure of 0.5 to 0.9 MPa)			
Required air flow rate*8	—		300 L/min (ANR)	
Temperature compensation function	Automatic			

\*1 Effective measuring range when contour light is used.

\*2 The specific combination of 1X, 2X and 4X or 1X, 2X, 4X and 6X is available by custom order.

\*3 Inspected to a Mitutoyo standard. L=length between two arbitrary points (mm)

\*4 Verified at shipment from factory.

\*5 The assured accuracy of UMAP is specific to that of UMAP110 in the case of a measuring speed of 10  $\mu\text{m/s}$ .

\*6 The accuracies are guaranteed for a measuring speed of 5  $\mu\text{m/s}$  for the UMAP101 and a measuring speed of 10  $\mu\text{m/s}$  for the UMAP103, 107, 110, and 130.

\*7 An excessively biased or concentrated load is excluded.

\*8 HYPER UMAP Vision System 302 TYPE2 only uses air to move UMAP up and down.

Note 1: The Laser Auto Focus (LAF) specification is available by custom order.

Note 2: Machines compatible with ISO10360-7: 2011 Accuracy Assurance are also available.

NOTE: Machines in this series are equipped with the main unit deactivating system (relocation detection system) that prevents the machine from operating if it is subjected to an unexpected vibration or if it is relocated. Be sure to contact your nearest Mitutoyo sales office prior to relocating this machine after initial installation.

## ULTRA UMAP Vision System 404 TYPE2



ULTRA QV404 PRO

- This is a high-end microscopic-form measuring system that is based on the ULTRA QV404 PRO ultra-accurate vision measuring machine.
- By applying an auto-suction air bearing to the Y axis and a floating mechanism to the ball screw parts of each axis, we have made possible measurements with even higher accuracy and stability.

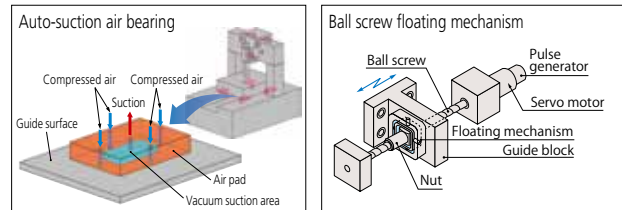

- The standard length measuring system uses a low-expansion glass scale with a linear expansion coefficient of  $(0 \pm 0.02) \times 10^{-6} \text{K}$ , which keeps glass scale expansion/contraction due to temperature changes to the absolute minimum.

## Dimensions

### HYPER UMAP 302

Unit: mm

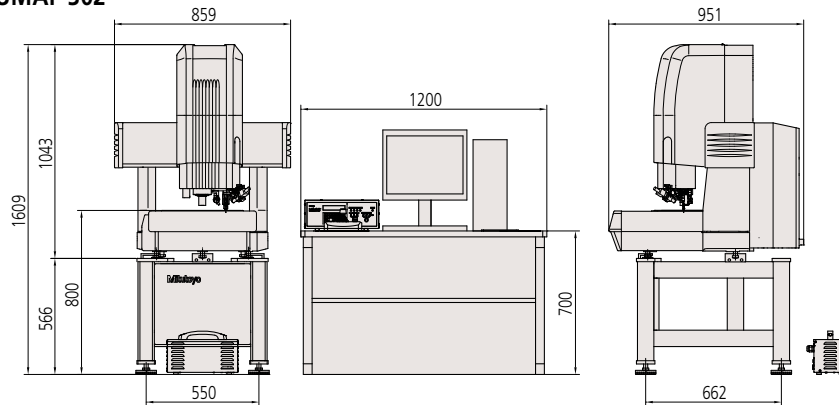

### ULTRA UMAP 404

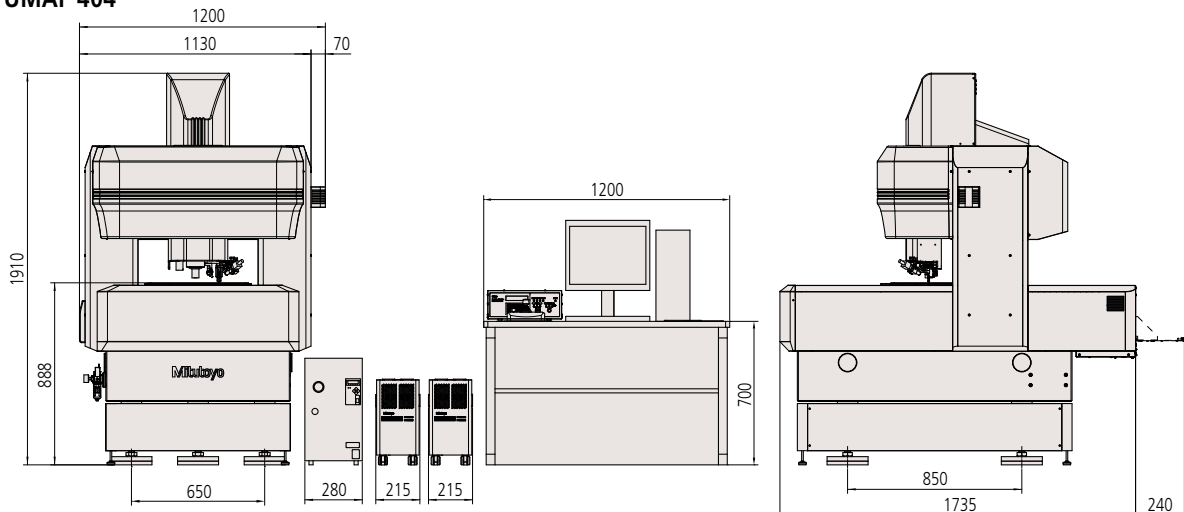



# Software

## QVPAK

QVPAK, the main software, supports both non-contact measurements using vision mode and contact measurements using UMAP mode.

Calculation function example

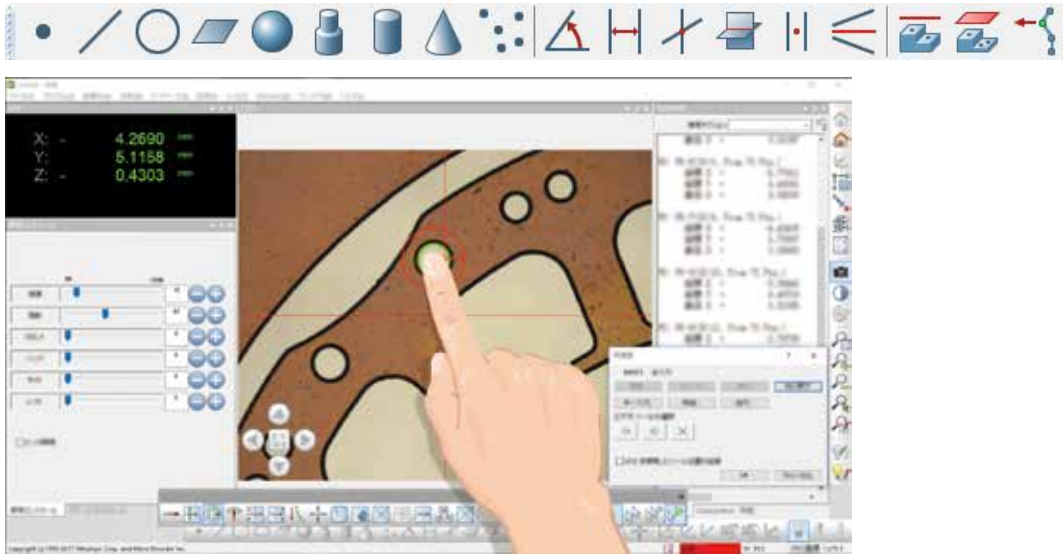

Gesture operation, like operating a smartphone, enables easy tool layout or stage shifting on systems with touch screens.

### Switching between vision and UMAP modes

The user can click icons to switch between vision and UMAP modes. This makes it possible to use vision mode to perform workpiece positioning and then use UMAP mode to perform targeted measurements.

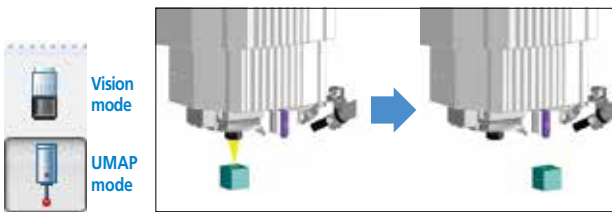

### Measuring tool arrangement with a single click

The tool size, orientation, and threshold of vision measuring tools are automatically set with one click of the mouse in the vicinity of the measurement location.

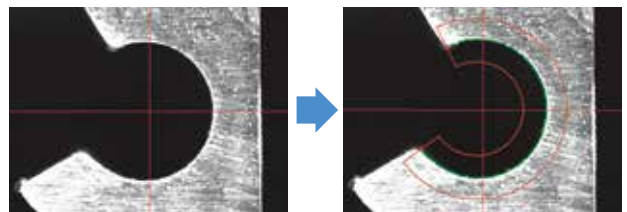

### Abnormal point removal

Abnormal points caused by dirt, burrs, and chips are removed automatically. Also, it is possible to determine the optimum removal level for abnormal points while viewing the measured data.

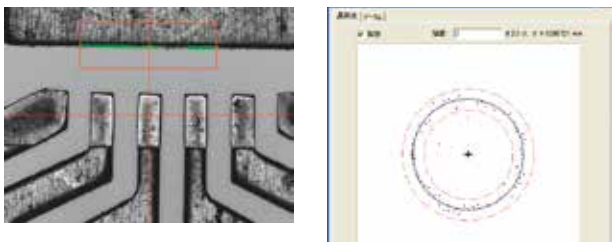

### QVGraphics

The elements measured with QVPAK and the measurement results can be displayed graphically. It is also possible to calculate distances and angles for configuring the coordinate system settings of displayed elements that the user specifies.

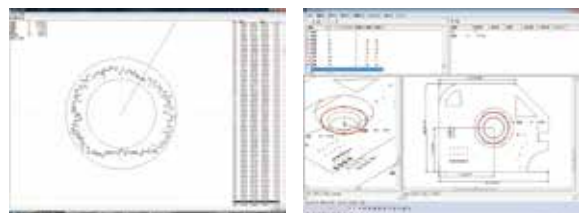

Drawing the geometrical deviation of a circle

Graphical display of a measured element

# Options

## FORMTRACEPAK-AP

This software makes it possible to use the point buffer data obtained in UMAP or vision mode as the base data for performing dimension analysis on microscopic forms and contour matching with the design data.

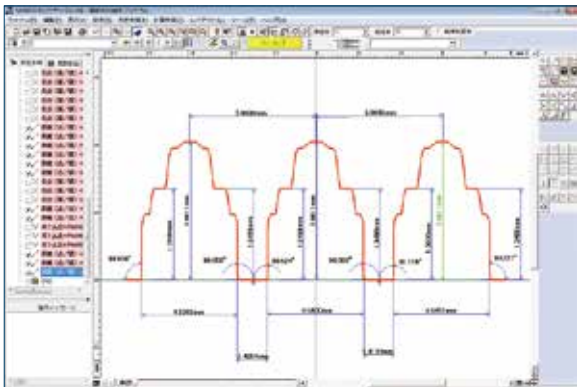

Microscopic dimension analysis example

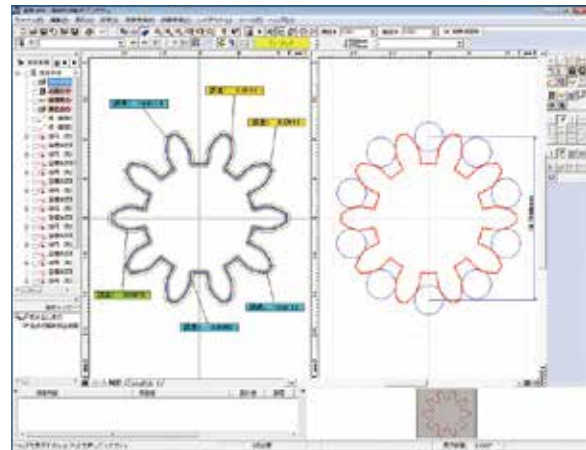

Gear contour matching and over-pin diameter analysis example

## Objectives

The objectives can be changed to give the observation magnification required or to suit the workpiece depth.



Objectives	Turret magnification	Monitor magnification	View field	Working distance*1
QV-SL0.5X*2	1X	15X	12.54x9.4	30.5
	2X	30X	6.27x4.7	
	6X	90X	2.09x1.56	
QV-SL1X QV-HR1X	1X	30X	6.27x4.7	52.5 40.6
	2X	60X	3.13x2.35	
	6X	180X	1.04x0.78	
QV-HR2.5X QV-SL2.5X	1X	75X	2.5x1.88	40.6 60
	2X	150X	1.25x0.94	
	6X	450X	0.41x0.31	
QV5X	1X	150X	1.25x0.94	33.5
	2X	300X	0.62x0.47	
	6X	900X	0.2x0.15	
QV-HR10X*2 QV-10X	1X	300X	0.62x0.47	20 30.5
	2X	600X	0.31x0.23	
	6X	1800X	0.1x0.07	
QV25X*2*3	1X	750X	0.25x0.18	13
	2X	1500X	0.12x0.09	
	6X	4500X	0.04x0.03	

\*1 Depending on the PRL position, the PRL illumination unit may be shorter than the working distance.

\*2 Depending on the workpiece, some limitations, such as the illumination being insufficient, may occur.

\*3 The usable position for PRL is restricted.

## Two-axis index table (Made-to-order product)

The combining of two index tables makes the UMAP Vision System extremely well suited to measurements of complicated forms on the sides of workpieces as well as slanted holes.





**Whatever your challenges are, Mitutoyo supports you from start to finish.**

Mitutoyo is not only a manufacturer of top quality measuring products but one that also offers qualified support for the lifetime of the equipment, backed up by comprehensive services that ensure your staff can make the very best use of the investment.

Apart from the basics of calibration and repair, Mitutoyo offers product and metrology training, as well as IT support for the sophisticated software used in modern measuring technology. We can also design, build, test and deliver bespoke measuring solutions and even, if deemed cost-effective, take your critical measurement challenges in-house on a sub-contract basis.

Note: Product illustrations are without obligation. Product descriptions, in particular any and all technical specifications, are only binding when explicitly agreed upon.  
 MITUTOYO and MICAT are either registered trademarks or trademarks of Mitutoyo Corp. in Japan and/or other countries/regions.  
 Other product, company and brand names mentioned herein are for identification purposes only and may be the trademarks of their respective holders.

Our products are classified as regulated items under Japanese Foreign Exchange and Foreign Trade Law. Please consult us in advance if you wish to export our products to any other country. If the purchased product is exported, even though it is not a regulated item (Catch-All controls item), the customer service available for that product may be affected. If you have any questions, please consult your local Mitutoyo sales office



**Mitutoyo Asia Pacific Pte. Ltd.**  
 Company Reg No. 197800892N  
**24 Kallang Avenue, Mitutoyo Building, Singapore 339415**  
**Tel: (65) 6294 2211 Fax: (65) 6299 6666**  
**E-mail: mapsg@mitutoyo.com.sg**



**www.mitutoyo.com.sg | www.mitutoyo.com.my**  
**www.mitutoyo.co.th | www.mitutoyo.co.id**  
**www.mitutoyo.com.vn | www.mitutoyo.com.ph**

**Mitutoyo (Malaysia) Sdn. Bhd.**  
 Mah Sing Integrated Industrial Park,  
 4, Jalan Utarid US/14, Section U5,  
 40150 Shah Alam, Selangor, Malaysia  
 Tel: (60) 3-7845 9318  
 Fax: (60) 3-7845 9346  
 E-mail: mmsb@mitutoyo.com.my  
**Penang Branch**  
 Tel: (60) 4-641 1998 Fax: (60) 4-641 2998  
**Johor Branch**  
 Tel: (60) 7-352 1626 Fax: (60) 7-352 1628

**Mitutoyo (Thailand) Co., Ltd.**  
 76/3-5, Chaengwattana Road, Kwaeng  
 Anusaawaree, Khet Bangkaen,  
 Bangkok 10220, Thailand  
 Tel: (66) 2080 3500  
 Fax: (66) 2521 6136  
 E-mail: office@mitutoyo.co.th  
**Chonburi Branch**  
 Tel: (66) 2080 3563 Fax: (66) 3834 5788  
**ACC Branch**  
 Tel: (66) 2080 3565

**PT. Mitutoyo Indonesia**  
 Jalan Sriwijaya No.26  
 Desa cibatu  
 Kec. Cikarang Selatan  
 Kab. Bekasi 17530, Indonesia  
 Tel: (62) 21-2962 8600  
 Fax: (62) 21-2962 8604  
 E-mail: ptmi@mitutoyo.co.id

**Mitutoyo Vietnam Co., Ltd.**  
 1st & 2nd Floor, MHDI Building,  
 No. 60 Hoang Quoc Viet Road,  
 Nghia Do Ward, Cau Giay District,  
 Hanoi, Vietnam  
 Tel: (84) 24-3768 8963  
 Fax: (84) 24-3768 8960  
 E-mail: mvc@mitutoyo.com.vn  
**Ho Chi Minh City Branch**  
 Tel: (84) 28-3840 3489  
 Fax: (84) 28-3840 3498  
**Hai Phong City Branch**  
 Tel: (84) 22-5398 9909

**Mitutoyo Philippines, Inc.**  
 Unit 1B & 2B LTI,  
 Administration Building 1,  
 Annex 1, North Main Avenue,  
 Laguna Technopark, Biñan,  
 Laguna 4024, Philippines  
 Tel: (63) 49-544 0272  
 Fax: (63) 49-544 0272  
 E-mail: mpi@mitutoyo.com.ph