

High-Accuracy Height Gage Linear Height LH-600F/FG

Small Tool Instruments and
Data Management



Easy operation and High-accuracy

In pursuit of intuitive operation and outstanding ease of use
Achieves best-in-class accuracy of $\pm (1.1+0.6L/600) \mu\text{m}$

High-Accuracy Height Gage Linear Height LH-600F/FG

- Easy operation using keypad and touch screen navigation, even suitable for beginners
- Conduct various measurements such as 2D measurement and perpendicularity measurement with just one tool
- Versatile measurements through optional probes
- Enhanced data output functions make it easier to manage your measurement data



Linear Height

Easy operation using keypad and touch screen navigation, even suitable for beginners

Contextual guidance on the large-screen touch panel supports your measurements



Simple, straightforward keys with icons

Icons allow the user to find the required operation at a glance.

Basic measurements

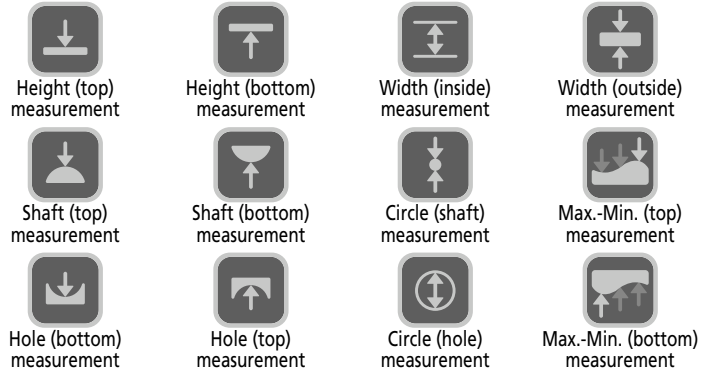

Advanced measurement functions

Power

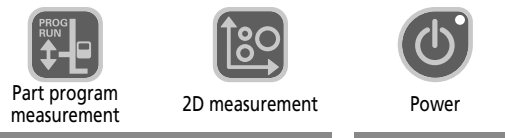

Measurement settings



Other

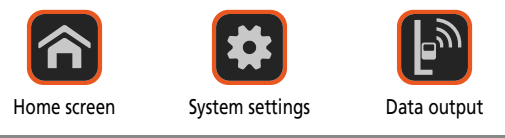

Touch panel with guidance

Measurement guidance is displayed on the large touch panel of the 8.4-inch color LCD, enabling intuitive operation.

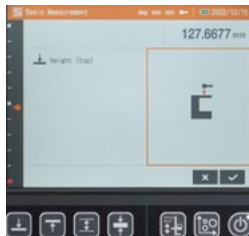

Guidance screen



Operable with gloves

Fantastic features for shop-floor use

Automatic scale check

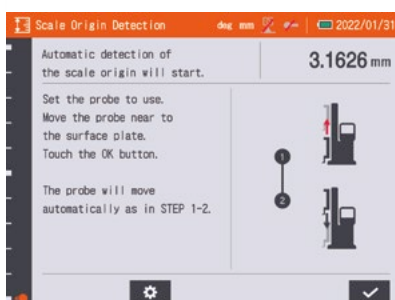

On start up the user is led through the menu to set the scale origin and run the automated procedure to check the scale for contamination.

Calibration reminder

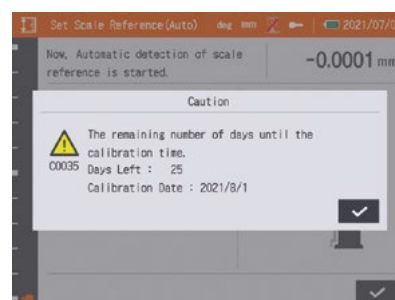

A notification will be displayed before the calibration due date that the user has set.

Home screen

With the intuitive menu, even beginners can easily access various operations and settings.

Touch panel
or
Sheet key

Measurement results

General settings

Measurements

- Basic measurements (ABS)
- Basic measurements (ABS, INCx5)
- Angle measurements
- Hole position measurements
- Perpendicularity and straightness measurements
- 2D measurements
- Part program measurements (1D, 2D)

Guidance and measurement navigation

Guidance is available in 21 languages. The display shows each measurement step and it's very easy to use even for beginner.

Select basic measurements

Select a measurement method

Conduct the measurement

View the measurement results

Operation log

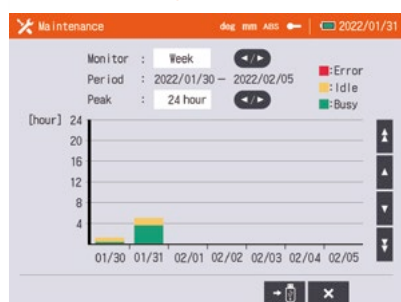

Operation log data is retained for up to 2 months, and can be output to a USB memory device.

Repeat measurement function

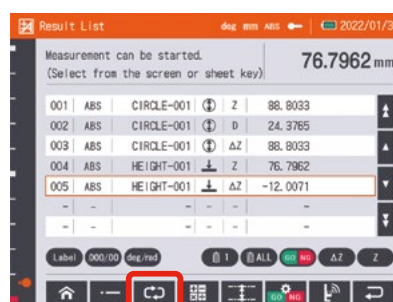

To enable efficient measurements the user can repeat the last measurement with the optional foot switch or on-screen button.

Various measurements with just one unit

Improved usability and accessibility, including advanced measurement functions

2D measurement - Pre-placement -

This function allows the user to register the hole position of the workpiece before measurement.

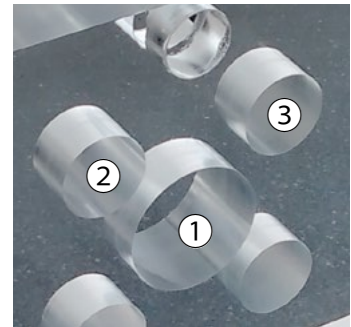
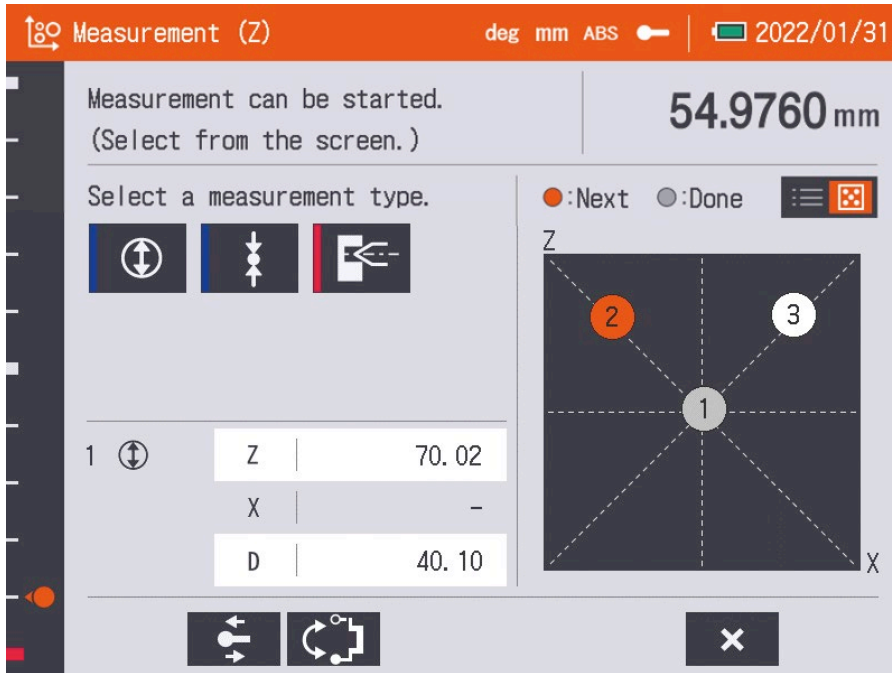

Perpendicular/straightness measurement - Graph creation -

You can check the measurement results of perpendicularity and straightness in real time during measurement. After measurement, you can easily see the trends of the measurement results in a graph.

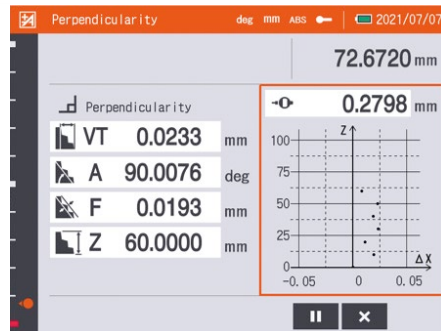

Show results in real time during measurement.

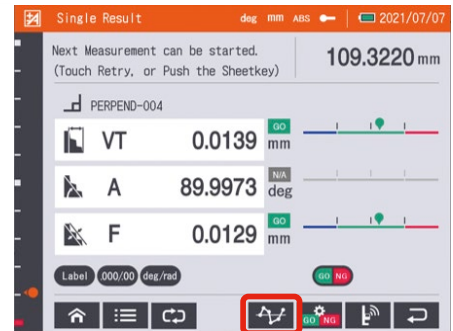

Show results after measurement.



You can monitor the graphs of past measurement results.



Show measurement results in graph form.

Part program measurement

You can easily access and use the functions of Create, Run, Edit, and View results of part programs.

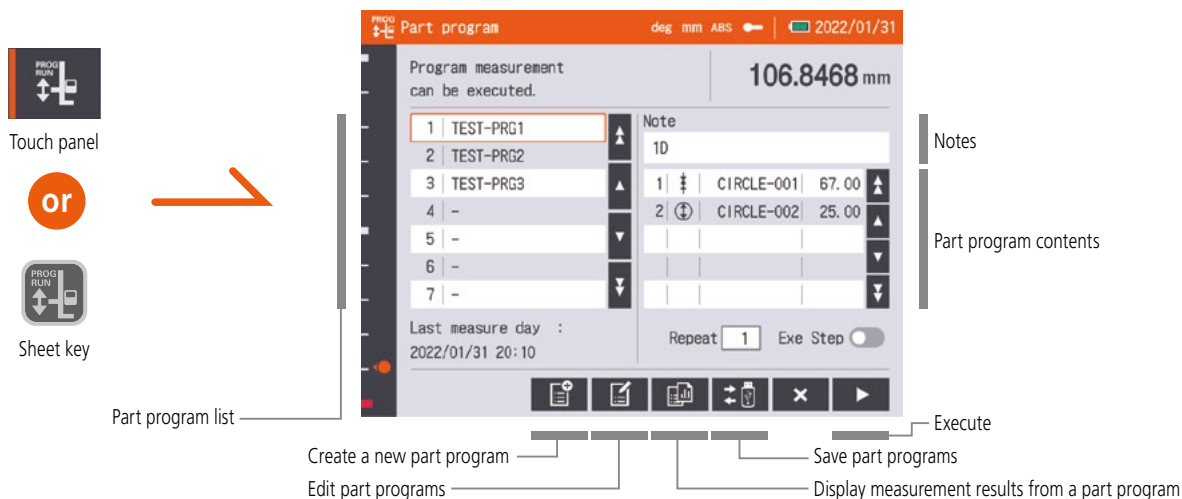

Example of performing part program measurement

Run the program repeatedly (when the number of executions is $\neq 1$)

Set the number of times to repeat measurements and run the program.

Run the registered contents one by one.

Display the result for one execution of the program.

Display all results for one execution of the program.

Display all results of N times of executing the program.

Copy part programs to other devices

By using a USB memory device, you can copy part programs to other devices.

Expanded measurement area

With the new optional probes, you can now measure areas that were beyond the capacity of conventional probes.

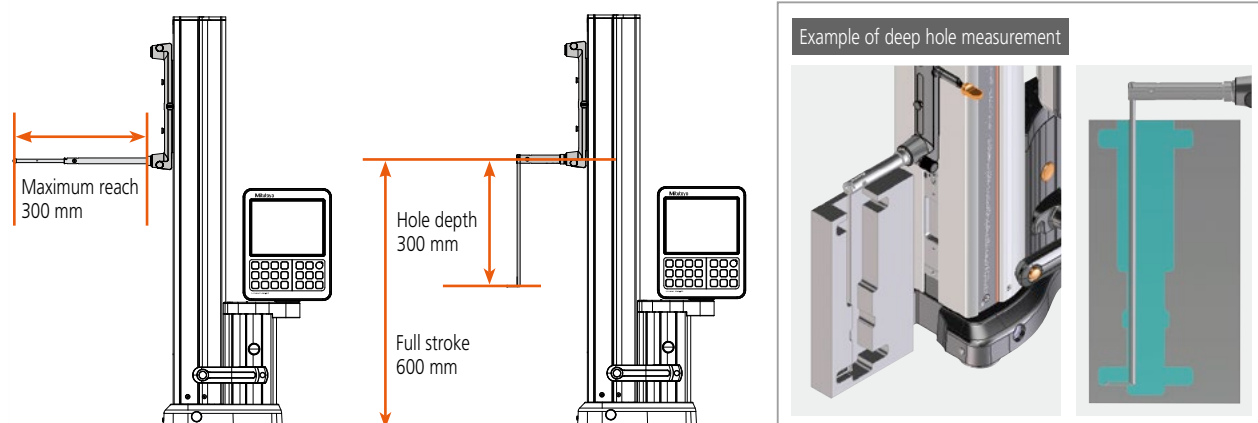

Versatile measurements through optional probes

An extension holder and a depth stylus extend the measuring range both horizontally and vertically

Three types of optional probes:

- ① The holder and the stylus can be freely combined according to the purpose of measurement, and the measurement area can be changed.
- ② This type is used for single-use measurements such as measuring a tapered hole or a knife edge.
- ③ This type is used to measure straightness and perpendicularity.
- ☆ You can adjust the balance of the slider by adjusting the number of auxiliary weights. (Magnetic auxiliary weights are easy to add and remove.)

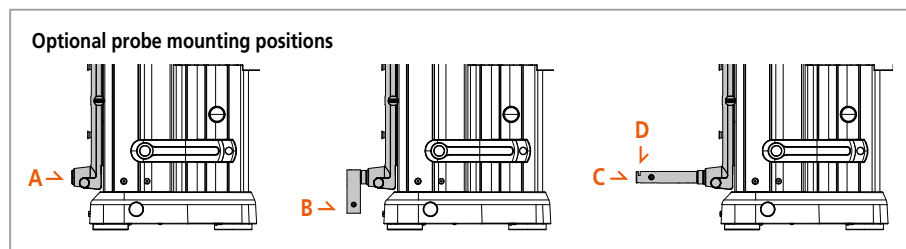
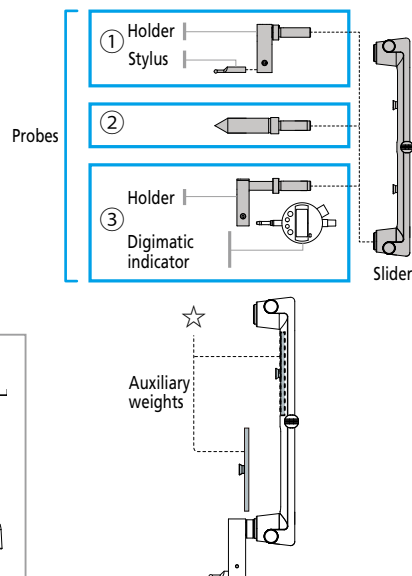











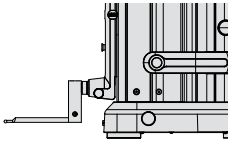

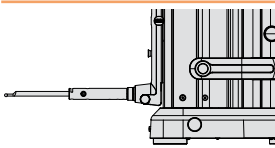







Holders/styli for position A

	Part No.	Product name	Number of weights
Mounting example For extension holder 100		12AAY343 ø5 stepped probe (standard accessory)	2
For depth measurement probes		12AAA792 Holder for Dial Indicator (millimeter)	0
		12AAA793 Holder (long)	*1
For taper stylus (ø20)		12AAB136 ø10 cylindrical universal probe	2
		12AAY595 Extension holder 100	*1
		12AAY596 Extension holder 200	*1
		12AAC072 Depth probe	2
		12AAC073 Tapered stylus (ø20)	2

*1: Please refer to page 8 for the number of weights to be used.









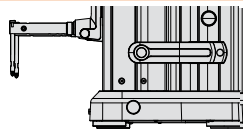

Styli for position B/C

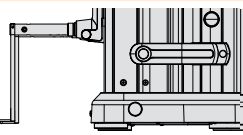
		Part No.	Product name	Number of weights ^{*3}
Mounting example Ø5 ball stylus L130 in position B 		12AAF666	ø1 ball stylus (coaxial type)	2
		957261	ø2 ball stylus (coaxial type)	2
Ø5 ball stylus L130 in position C 		12AAF667	ø2 ball stylus (coaxial type), ruby ball	2
		957262	ø3 ball stylus (coaxial type)	2
		957263	ø4 ball stylus (coaxial type)	2
		12AAB552	ø10 ball stylus (coaxial type), L=50	2
		12AAF668	ø10 ball stylus (coaxial type), L=82	1
		12AAF669	ø10 ball stylus (coaxial type), L=120	1
		12AAF670	ø5 disk stylus	2
		12AAF671	ø10 disk stylus	2
		957264	ø14 disk stylus	2
		957265	ø20 disk stylus	2
		12AAF672	ø1 ball stylus (eccentric type)	2
		12AAF673	ø2 ball stylus (eccentric type)	2
	12AAA788	ø4 ball stylus (eccentric type)	2	
	12AAA789	ø6 ball stylus (eccentric type)	1	
	226117	Shank with M2 thread ^{*2}	2	
	226118	Shank with M3 thread ^{*2}	2	
	12AAY597	ø5 ball stylus L130	1	
	12AAY598	ø25 disk stylus	1	

*2: Stylus for coordinate measuring machine can be mounted. *3: When using an extension holder. Note: Where the material is not described, the tip of the stylus is carbide.

Styli for position D

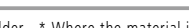
		Part No.	Product name	Number of weights ^{*4}
Mounting example Depth stylus 70 is mounted in position D 		12AAY599	Depth stylus 70	2
		12AAY600	Depth stylus 150	1
Depth stylus 150 ø4 ball is mounted in position D 		12AAY601	Depth stylus 300	0
		12AAY602	Depth stylus 70 ø2 ball	2
		12AAY603	Depth stylus 150 ø2 ball	1
		12AAY604	Depth stylus 300 ø2 ball	0
		12AAY605	Depth stylus 70 ø4 ball	2
		12AAY606	Depth stylus 150 ø4 ball	1
		12AAY607	Depth stylus 300 ø4 ball	0

*4: Can only be attached to the extension holder. * Where the material is not described, the tip of the stylus is carbide.

Enhanced data output functions make it easier to manage your measurement data

Data output improves work efficiency and the reliability of recorded data

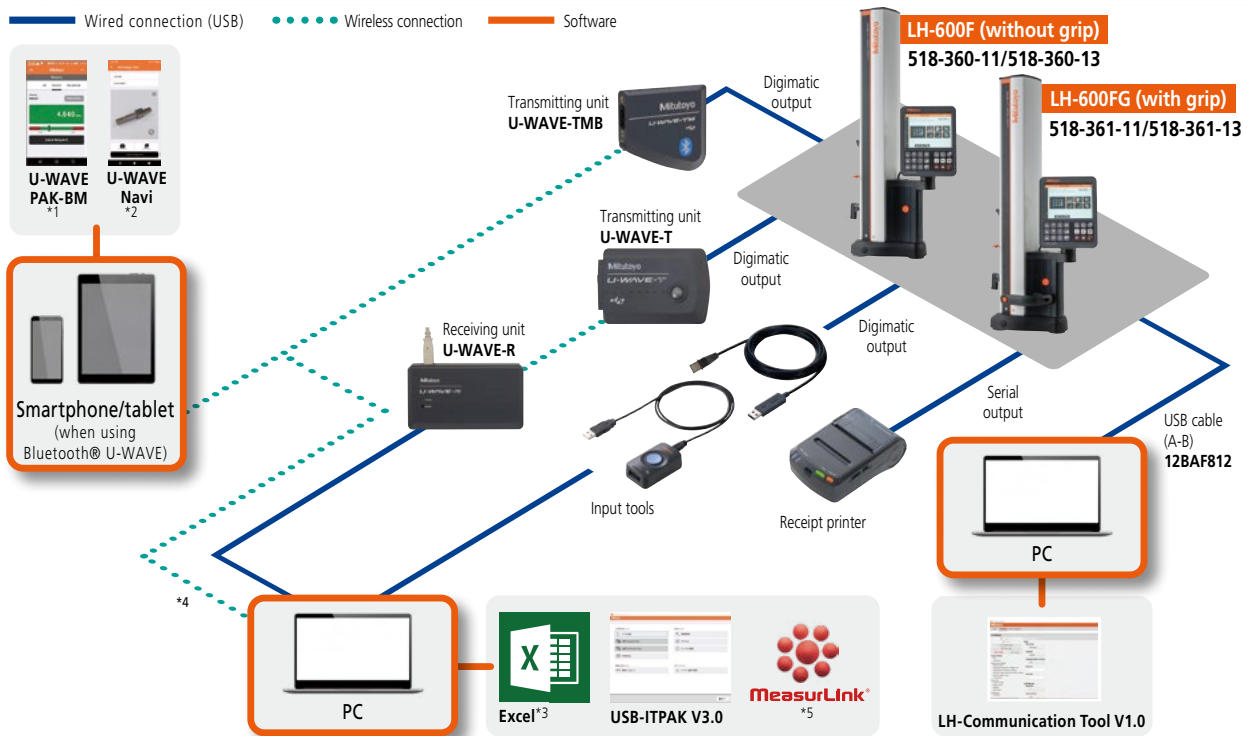

*1: Available at Apple Store and Google Play for free download. *2: Available at Google Play for free download.
 *3: Excel is a registered trademark of Microsoft Corporation. *4: It is also possible to connect with a Bluetooth compatible PC.
 *5: MeasurLink® is a registered trademark of Mitutoyo Corporation (Japan) and Mitutoyo America Corporation (USA).

Optional products for outputting measurement data

Part No.	Product name
12AA481	Receipt printer (for Japan) ^{*6}
12AA482	Receipt printer (for North America) ^{*6}
12AA483	Receipt printer (for EU countries, excluding the UK) ^{*6}
12AA484	Receipt printer (for the UK) ^{*6}
12AAN052	Printer paper for receipt printer (set of 10)
12AA485	Printer mounting attachment
12AAN146	Connection cable for printer (USB memory device) ^{*7}
12BAF812	USB cable (type A - type B) (2 m)
543-700B	Digimatic indicator (ID-C0512NXB)
543-701B	Digimatic indicator (ID-C0512MNXB)
519-521	Lever head probe MLH-521
519-561	Mu-checker M-561

*6: A small printer (optionally battery-powered) that can be mounted on the main unit. It includes a printer cable and mounting bracket.
 *7: USB memory devices should be formatted with FAT16/32. NTFS and exFAT are not supported.

Part No.	Product name
936937	Digimatic cable (1 m)
965014	Digimatic cable (2 m)
264-505	Digimatic mini processor (DP-1VA)
06AGQ001F	Input tool (USB-ITN-SF)
264-020	Input tool (IT-020U)
06AGL011	Bidirectional digimatic S1 cable, Flat and straight (1 m)
06AGL021	Bidirectional digimatic S1 cable, Flat and straight (2 m)
12AAJ088	Foot switch
02AZD810D	U-WAVE-R
264-626	U-WAVE-TMB (IP67 type)
264-627	U-WAVE-TMB (Buzzer type)
02AZD730G	U-WAVE-T (IP67 type)
02AZD880G	U-WAVE-T (Buzzer type)
12AA486	U-WAVE T mounting bracket
02AZG011	Bidirectional Diamic S1 cable (160 m)

LH-Communication Tool V1.0 software for creating inspection reports and configuring system settings

You can easily create and save inspection reports and configure device parameters.

* Available at Mitutoyo website for free download.
 * To connect to a PC, use a USB cable (type A-B).

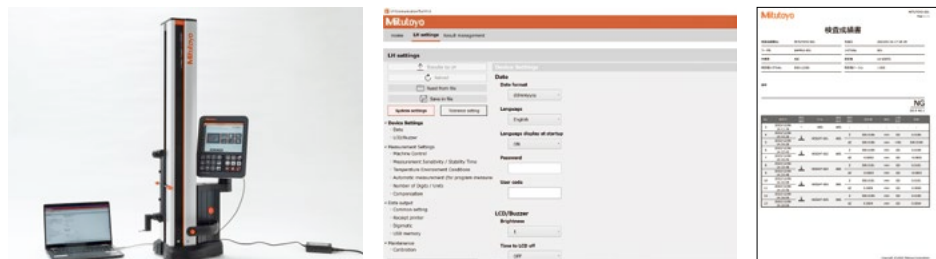

Specifications

Model		LH-600F	LH-600FG
Order No.	mm	518-360-11	518-361-11
	inch/mm	518-360-13	518-361-13
Power grip		without power grip	with power grip
Measuring range (Stroke)		0 to 977 mm (600 mm) 0 to 38 in (24 in)	
Resolution		0.0001/0.001/0.01/0.1 mm (selectable) 0.000001/0.00001/0.0001/0.001 in (selectable)	
Accuracy (at 20 °C)	Indication accuracy* ⁸	$\pm (1.1 + 0.6L / 600) \mu\text{m}$, L= Measured length (mm)	
	Repeatability* ⁸	Plane: 0.4 μm (2 σ), Hole: 0.9 μm (2 σ)	
	Perpendicularity (forward and backward)* ⁹	5 μm (after compensation)	
	Straightness (forward and backward)* ⁹	4 μm (mechanical accuracy)	
Driving method(speed)		Motor-driven (5, 10, 15, 20, 25, 30, 40 mm/s: 7 steps) / Manual	
Scale unit		Photoelectric incremental encoder STVC-20Z	
Measuring force		1 N (automatic constant-force function)	
Main unit moving mode		Full-floating (moving) / Semi-floating (measuring) Air bearing (built-in compressor)	
Display unit		8.4 inch touch-screen, LCD	
Adjustment of display unit		Stepless tilt adjustment: 0 to 40° Stepless swivel adjustment: -30 to 180°	
Preventive maintenance		Scale status notification, calibration schedule notification	
Probe diameter compensation		· Semi-automatic compensation using the probe diameter calibration block (standard accessory) · Compensation by inputting the probe diameter	
Power supply		AC adapter 100-240V \pm 10% 50/60Hz/ Battery (NiMH)	
Battery operation time* ¹⁰		Battery powered(standard): 4 hours, Powered by 2 batteries: 8 hours	
Battery charging time* ¹¹		Approx. 3.5 hours (can be used while charging)	
Dimensions (WxDxH)		238 (W) x 492 (D) x 996 (H) mm	
Mass		26.1 kg	26.6 kg
Operating temperature / humidity ranges		5 to 40 °C/ 20 to 80% RH (non-condensing)	
Data output		Digimatic d2/ S1 (bi-directional communication)	

*8: Specification determined at in-house ambient temperature

*10: In-house standard(floating and motor-driven vertical movement, operated at 25%)

*9: Guaranteed when using the Lever Head (519-521) and Mu-Checker (519-561).

*11: When ambient temperature is 30 °C or higher, the battery may not be charged sufficiently.

Dimensions

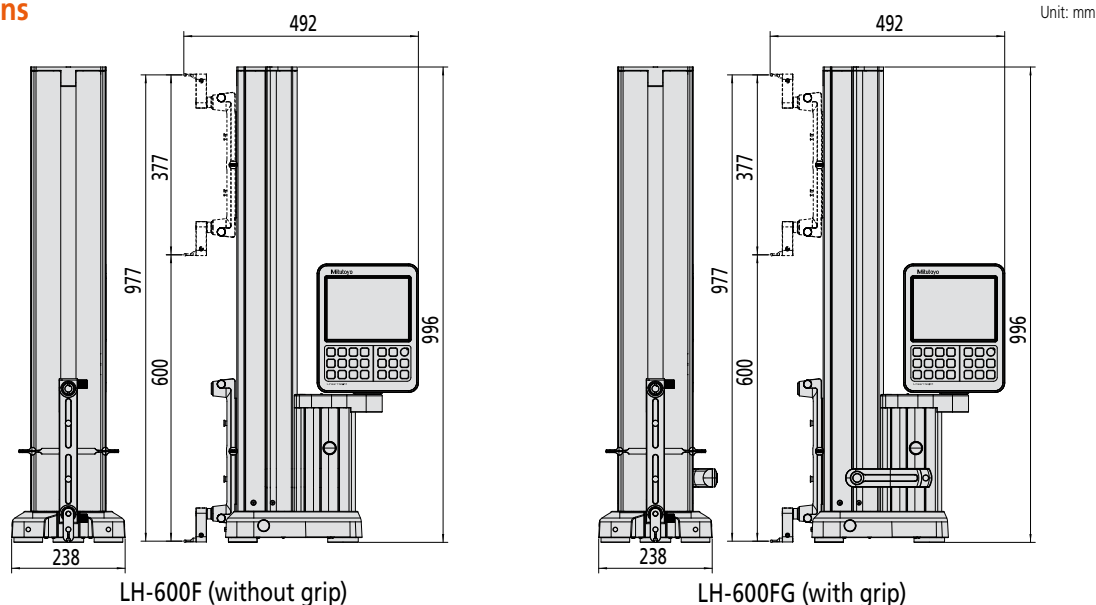

Unit: mm

Standard accessories

Ø5 stepped probe, ball-diameter compensation block (with cover and base), auxiliary weight (2 pcs. pre-mounted), battery pack (1 pc)^{*12}, AC adapter, power cable for AC adapter (optional), clear cover, conveying handle, cap, hex wrench, manual set, inspection certificate, Touch pen, protective sheet, Phillips screwdriver

*12: One piece included as standard. Optional additional battery (using total of two batteries) for longer battery-powered operation.

Special accessories

Additional battery pack (Part No.: **12AAF712**), model workpiece (Part No.: **12AAA879**)

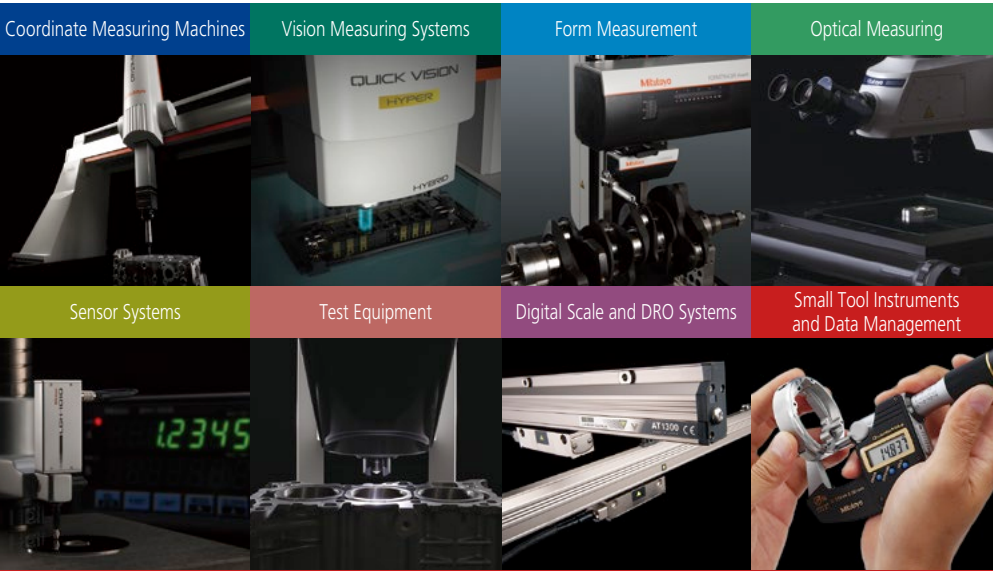

Whatever your challenges are, Mitutoyo supports you from start to finish.

Mitutoyo is not only a manufacturer of top quality measuring products but one that also offers qualified support for the lifetime of the equipment, backed up by comprehensive services that ensure your staff can make the very best use of the investment.

Apart from the basics of calibration and repair, Mitutoyo offers product and metrology training, as well as IT support for the sophisticated software used in modern measuring technology. We can also design, build, test and deliver measuring solutions and even, if deemed cost-effective, take your critical measurement challenges in-house on a sub-contract basis.

Note: Product illustrations are without obligation. Product descriptions, in particular any and all technical specifications, are only binding when explicitly agreed upon.

MITUTOYO and MiCAT are either registered trademarks or trademarks of Mitutoyo Corp. in Japan and/or other countries/regions.

Other product, company and brand names mentioned herein are for identification purposes only and may be the trademarks of their respective holders.



www.mitutoyo.com.sg | www.mitutoyo.com.my
www.mitutoyo.co.th | www.mitutoyo.co.id
www.mitutoyo.com.vn | www.mitutoyo.com.ph

Small Tools Authorized Distributor

Mitutoyo

Mitutoyo Asia Pacific Pte. Ltd.

Company Reg No. 197800892N

24 Kallang Avenue, Mitutoyo Building, Singapore 339415

Tel: (65) 6294 2211 Fax: (65) 6299 6666

E-mail: mapsg@mitutoyo.com.sg

Mitutoyo (Malaysia) Sdn. Bhd.

Mah Sing Integrated Industrial Park,
4, Jalan Utarid U5/14, Section U5,
40150 Shah Alam, Selangor, Malaysia

Tel: (60) 3-7845 9318

Fax: (60) 3-7845 9346

E-mail: mmsb@mitutoyo.com.my

Penang Branch

Tel: (60) 4-641 1998

Fax: (60) 4-641 2998

Johor Branch

Tel: (60) 7-352 1626

Fax: (60) 7-352 1628

Mitutoyo (Thailand) Co., Ltd.

76/3-5, Chaengwattana Road, Kwaeng
Anusaowaree, Khet Bangkaen,
Bangkok 10220, Thailand

Tel: (66) 2080 3500

Fax: (66) 2521 6136

E-mail: office@mitutoyo.co.th

Chonburi Branch

Tel: (66) 2080 3563

Fax: (66) 3834 5788

ACC Branch

Tel: (66) 2080 3565

PT. Mitutoyo Indonesia

Jalan Sriwijaya No.26
Desa cibatu
Kec. Cikarang Selatan
Kab. Bekasi 17530, Indonesia

Tel: (62) 21-2962 8600

Fax: (62) 21-2962 8604

E-mail: ptmi@mitutoyo.co.id

Mitutoyo Vietnam Co., Ltd.

1st & 2nd Floor, MHDH Building,
No. 60 Hoang Quoc Viet Road,
Nghia Do Ward, Cau Giay District,
Hanoi, Vietnam

Tel: (84) 24-3768 8963

Fax: (84) 24-3768 8960

E-mail: mvc@mitutoyo.com.vn

Ho Chi Minh City Branch

Tel: (84) 28-3840 3489

Fax: (84) 28-3840 3498

Hai Phong City Branch

Tel: (84)22-5398 9909

Mitutoyo Philippines, Inc.

Unit 1B & 2B LTI,
Administration Building 1,
Annex 1, North Main Avenue,
Laguna Technopark, Biñan,
Laguna 4024, Philippines

Tel: (63) 49-544 0272

Fax: (63) 49-544 0272

E-mail: mpi@mitutoyo.com.ph